

129-194

SERVO CONNECTOR KIT

for FX04, FX20, FX50

The FX04, FX20 and FX50 servos are shipped without connectors. There may be times when connectors are desired rather than direct connection. The purpose of this 129-194 servo connector kit is to assist the user in adding connector(s) to the servo.

The male connector supplied with the 129-194 kit is suitable for all servo types. The connector consists of 5 wires, each wire color coded to facilitate installation.

Each servo provides two connector locations, designated as left side and right side. If only one connector is to be inserted, it must first be decided if the left or the right will be inserted. The wire lengths from the connector seating to the internal terminal block are different depending on servo type and whether the connector will be left side or right side. Follow the diagrams and instructions below.

FX04 CONNECTOR INSTALLATION

Decide if the connector is being installed on Left or Right Side and cut wires to length per appropriate figure shown below. Strip all wires to 3/16" (4.7mm).

Prior to inserting the connector(s) into the servo it is recommended to apply RTV to the first two threads. The required torque is 88 in/lb.

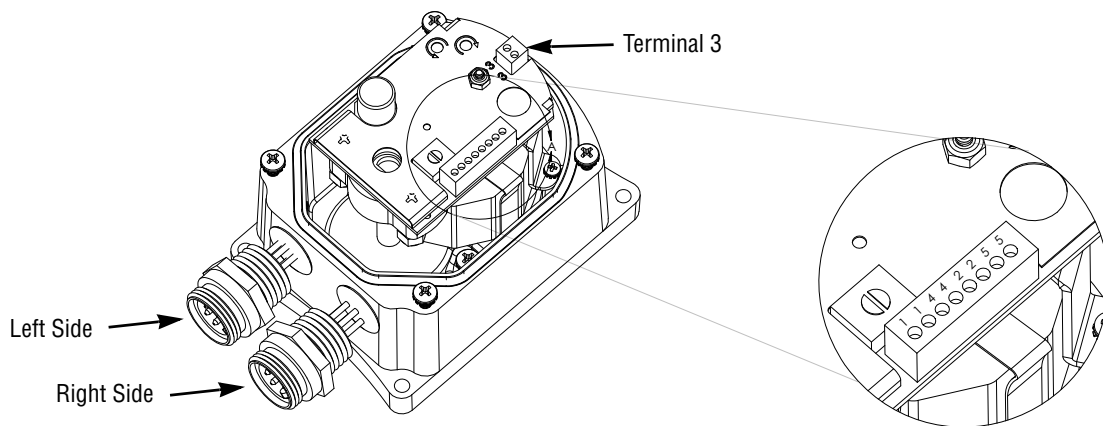

Table 1 FX04, LEFT SIDE

Wire Color	Wire Length	Terminal
Black	4.5" (115mm)	1
Brown	4.5" (115mm)	4
Blue	4.5" (115mm)	2
White	4.75" (121mm)	5
Yellow/Green	6" (153mm)	3

Table 2 FX04, RIGHT SIDE

Wire Color	Wire Length	Terminal
Black	3.5" (89mm)	1
Brown	3.5" (89mm)	4
Blue	3.5" (89mm)	2
White	3.75" (96mm)	5
Yellow/Green	6" (153mm)	3

1. Be aware of the terminal block numbering sequence. See detail shown above.
2. Route wires as specified in table to terminal.
3. Insert wire and secure in place with screw.

4. When complete, gather wires together and hold in place with tie wrap supplied with kit.
5. Tuck wires down inside housing wall being sure installation of the cover does not pinch any wires.

Note: The Yellow/Green wire from the Left Side connector is routed along the left side of the servo to get to terminal 3. All other wires from both the Left Side and Right Side connectors are routed along the right side of the servo.

FX20 CONNECTOR INSTALLATION

Decide if the connector is being installed on Left or Right Side and cut wires to length per appropriate figure shown below. Strip all wires to 3/16" (4.7mm).

Prior to inserting the connector(s) into the servo it is recommended to apply RTV to the first two threads. The required torque is 88 in/lb

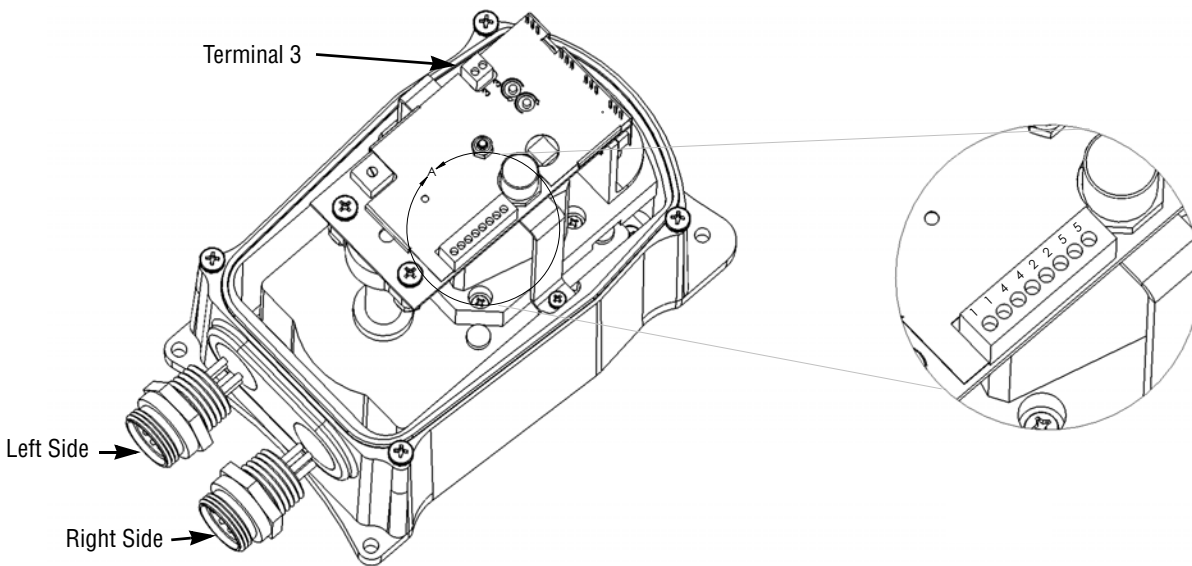

Table 3 FX20, LEFT SIDE

Wire Color	Wire Length	Terminal
Black	6.0" (153mm)	1
Brown	6.0" (153mm)	4
Blue	6.0" (153mm)	2
White	6.0" (153mm)	5
Yellow/Green	6.0" (153mm)	3

Table 4 FX20, RIGHT SIDE

Wire Color	Wire Length	Terminal
Black	5.0" (127mm)	1
Brown	5.0" (127mm)	4
Blue	5.0" (127mm)	2
White	5.0" (127mm)	5
Yellow/Green	7.0" (178mm)	3

1. Be aware of the terminal block numbering sequence. See detail shown above.
2. Route wires as specified in table to terminal.
3. Insert wire and secure in place with screw.
4. When complete, gather wires together and hold in place with tie wrap supplied with kit.
5. Tuck wires down inside housing wall being sure installation of the cover does not pinch any wires.

Note: The Yellow/Green wire from the Left and Right Side connectors are routed along the left side of the servo to get to terminal 3. All other wires from both the Left Side and Right Side connectors are routed along the right side of the servo

FX50 CONNECTOR INSTALLATION

Decide if the connector is being installed on Left or Right Side and cut wires to length per appropriate figure shown below. Strip all wires to 3/16" (4.7mm).

Prior to inserting the connector(s) into the servo it is recommended to apply RTV to the first two threads. The required torque is 88 in/lb.

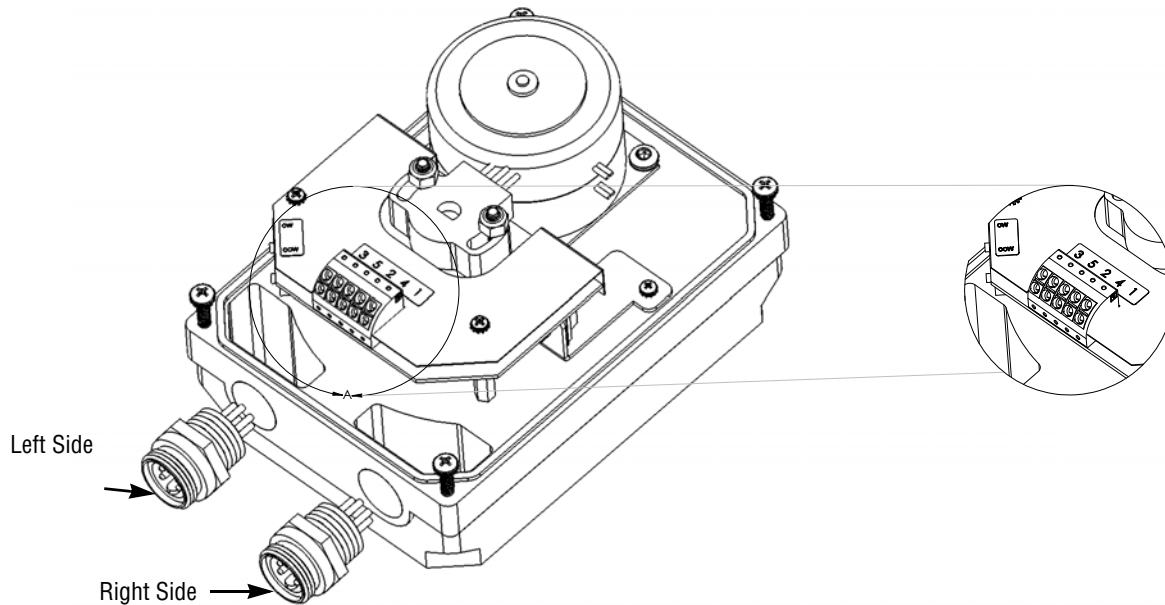

Table 5 FX50, LEFT SIDE

Wire Color	Wire Length	Terminal
Black	6.0" (153mm)	1
Brown	6.0" (153mm)	4
Blue	6.0" (153mm)	2
White	6.0" (153mm)	5
Yellow/Green	6.0" (153mm)	3

Table 6 FX50, RIGHT SIDE

Wire Color	Wire Length	Terminal
Black	5.0" (127mm)	1
Brown	5.0" (127mm)	4
Blue	5.0" (127mm)	2
White	5.0" (127mm)	5
Yellow/Green	7.0" (178mm)	3

1. Be aware of the terminal block numbering sequence. See detail shown above.
2. Route wires as specified in table to terminal.
3. Insert wire and secure in place with screw.
4. When complete, gather wires together and hold in place with tie wrap supplied with kit.
5. Tuck wires down inside housing wall being sure installation of the cover does not pinch any wires.



FIREYE®
3 Manchester Road
Derry, New Hampshire 03038 USA
www.fireeye.com

133-755
MAY 6, 2013
supersedes Aug 29, 2011