

# ACS580-0P

Supplement Installation Manual for ACS580-0P  
ACS580-0P Enclosed Drives (230V, 1-100 HP; 480V, 1-200 HP;  
575, 2-150 HP)







## Safety instructions

These are the safety instructions which you must obey when you install and operate the drive and do maintenance on the drive. If you ignore the safety instructions, injury, death or damage can occur.

### Use of warnings and notes in this manual

Warnings tell you about conditions which can cause injury or death, or damage to the equipment. They also tell you how to prevent the danger. Notes draw attention to a particular condition or fact, or give information on a subject.

The manual uses these warning symbols:

	<b>Electricity warning</b> tells about hazards from electricity which can cause injury or death, or damage to the equipment.
	<b>General warning</b> tells about conditions, other than those caused by electricity, which can cause injury or death, or damage to the equipment.
	<b>Electrostatic sensitive devices warning</b> tells you about the risk of electrostatic discharge which can cause damage to the equipment.

### General safety in installation, start-up and maintenance

These instructions are for all personnel that install the drive and do maintenance work on it.

 **WARNING!** Obey these instructions. If you ignore them, injury or death, or damage to the equipment can occur.

- Use safety shoes with a metal toe cap to avoid foot injury. Wear protective gloves and long sleeves. Some parts have sharp edges.

- Handle the drive carefully.
  - Frames R5...R9: Lift the drive with a lifting device. Use the lifting eyes of the drive.
  - Frames R5...R9: Do not tip the drive over. The drive is heavy and its center of gravity is high. An overturning drive can cause physical injury.



- Beware of hot surfaces. Some parts, such as heatsinks of power semiconductors, remain hot for a while after disconnection of the electrical supply.
- Keep the drive in its package or protect it otherwise from dust and burr from drilling and grinding until you install it.
- Vacuum clean the area below the drive before the start-up to prevent the drive cooling fan from drawing the dust inside the drive.
- Do not cover the air inlet and outlet when the drive runs.
- Make sure that there is sufficient cooling. See the *ACS580 Hardware Manual*

(3AXD50000044794) and *Quick Start Guide* (3AXD50000049129) for more information.

- Before you connect voltage to the drive, make sure that the drive covers are on. Keep the covers on during the operation.
- Before you adjust the drive operation limits, make sure that the motor and all driven equipment can operate throughout the set operation limits.
- Before you activate the automatic fault reset or automatic restart functions of the drive control program, make sure that no dangerous situations can occur. These functions reset the drive automatically and continue operation after a fault or supply break. If these functions are activated, the installation must be clearly marked as defined in IEC/EN 61800-5-1, subclause 6.5.3, for example, "THIS MACHINE STARTS AUTOMATICALLY".
- The maximum number of drive power-ups is five in ten minutes. Too frequent power-ups can damage the charging circuit of the DC capacitors.
- If you have connected safety circuits to the drive (for example, emergency stop and Safe torque off), validate them at the start up. For the validation of the Safe Torque Off, see *ACS580 firmware manual* (3AXD50000016097 [English]). For the validation of other safety circuits, see the instructions provided with them.

**Note:**

- If you select an external source for start command and it is on, and the start command is level-triggered, the drive will start immediately after fault reset. See parameters 20.02 Ext1 start trigger type and 20.07 Ext2 start trigger type in *ACS580 control program firmware manual* (3AXD50000016097 [English]).
- When the control location is not set to Local (text Hand is not shown on the top row of the panel and parameter 19.19 Off mode disable has value Off button disabled), the

stop key on the control panel will not stop the drive.

- Frames R1...R5: Do not attempt to repair a malfunctioning drive; contact your local representative for replacement or repair by authorized persons.
- Frames R6...R9: Can be repaired by authorized persons.

## Electrical safety in installation, start-up and maintenance

### Precautions before electrical work

These warnings are for all personnel who do work on the drive, motor cable or motor.

 **WARNING!** Frames R1 ... R9: Obey these instructions. If you ignore them, injury or death, or damage to the equipment can occur. If you are not a qualified electrical professional, do not do electrical installation or maintenance work. Go through these steps before you begin any installation or maintenance work.

1. Clearly identify the work location.
2. Disconnect all possible voltage sources. Lock and tag.
  - Open the main disconnect at the power supply of the drive.
  - Make sure that reconnection is not possible.
  - Disconnect any external power sources from the control circuits
  - After you disconnect the drive, always wait for 5 minutes to let the intermediate circuit capacitors discharge before you continue.
3. Protect any other energized parts in the work location against contact.
4. Take special precautions when close to bare conductors.



5. Measure that the installation is de-energized.
- Use a multimeter with an impedance of at least 1 Mohm.
  - Make sure that the voltage between the drive input power terminals (L1, L2, L3) and the grounding terminal (PE) is close to 0 V.

Frames R1...R3: Measure the voltage between the drive UDC+ terminal and grounding terminal (PE) with one multimeter. As there is no UDC- terminal, measure the voltage between the drive T1/U terminal and grounding terminal (PE) with another multimeter. Make sure that the voltage difference between the multimeters is close to 0 V.

Frames R4...R9: Measure the voltage between the drive DC terminals (UDC+ and UDC-) and the grounding terminal (PE) and make sure that it is close to 0 V.

6. Install temporary grounding as required by the local regulations.
7. Ask for a permit to work from the person in control of the electrical installation work.

If the drive does not operate according to these steps, refer to the *ACS580-01 Hardware Manual (3AXD50000044794)* and *Quick Start Guide (3AXD50000049129)*.

#### Additional instructions and notes

 **WARNING!** Obey these instructions. If you ignore them, injury or death, or damage to the equipment can occur.

- If the drive will be connected on an IT system (ungrounded or high-resistance-grounded [over 30 ohms]), make sure neither the EMC filter nor the ground-to-phase varistor are connected (metal screws should not be installed). Connections with metal screws in these systems can cause danger or damage. See section [Checking the compatibility with IT \(ungrounded\) and corner-grounded TN systems \(North America\)](#) in *ACS580 Hardware Manual*.

**Note:** For other systems, connecting the internal EMC filter will reduce the conducted emission.

- If the drive will be connected on a corner-grounded TN system, make sure the EMC filter is not connected (metal screws should not be installed). Connections with metal screws in these systems can cause danger or damage. See section [Checking the compatibility with IT \(ungrounded\) and corner-grounded TN systems \(North America\)](#) in *ACS580 Hardware Manual*.

**Note:** For other systems, connecting the internal EMC filter (using metal screws) will reduce the conducted emission.

- Use all ELV (extra low voltage) circuits connected to the drive only within a zone of equipotential bonding, that is, within a zone where all simultaneously accessible conductive parts are electrically connected to prevent hazardous voltages appearing between them. You can accomplish this by a proper factory grounding, that is, make sure that all simultaneously accessible conductive parts are grounded to the protective earth (PE) bus of the building.
- Do not do insulation or voltage withstand tests on the drive or drive modules.

#### Note:

- The motor cable terminals of the drive are at a dangerous voltage when the input power is on, regardless of whether the motor is running or not.
- The DC and brake resistor terminals (UDC+, UDC-, R+ and R-) are at a dangerous voltage.
- External wiring can supply dangerous voltages to the terminals of relay outputs (RO1, RO2 and RO3).
- The Safe torque off function does not remove the voltage from the main and auxiliary circuits. The function is not effective against deliberate sabotage or misuse.

 **WARNING!** Use a grounding wrist band when you handle the printed circuit boards. Do not touch the boards unnecessarily.

The boards contain components sensitive to electrostatic discharge.

## Grounding

These instructions are for all personnel who are responsible for the electrical installation, including the grounding of the drive.



**WARNING!** Obey these instructions. If you ignore them, injury or death, or equipment malfunction can occur, and electromagnetic interference can increase.

- If you are not a qualified electrical professional, do not do grounding work.
  - Always ground the drive, the motor and adjoining equipment to the protective earth (PE) bus of the power supply. This is necessary for the personnel safety. Proper grounding also reduces electromagnetic emission and interference.
  - In a multiple-drive installation, connect each drive separately to the protective earth (PE) bus of the power supply.
  - Make sure that the conductivity of the protective earth (PE) conductors is sufficient. See section [Power cable terminal and lead-through data](#) in *ACS580 Hardware Manual*. Obey the local regulations.
  - Connect the power cable shields to the protective earth (PE) terminals of the drive.
  - Standard IEC/EN & UL 61800-5-1 (section 4.3.5.5.2.) requires that as the normal touch current of the drive is higher than 3.5 mA AC or 10 mA DC, you must use a fixed protective earth (PE) connection. In addition,
    - install a second protective earth conductor of the same cross-sectional area as the original protective earthing conductor,
- or
- install a protective earth conductor with a cross-section of at least 7 AWG (10 mm<sup>2</sup>) Cu,
- or

- install a device which automatically disconnects the supply if the protective earth conductor breaks.

## Additional instructions for permanent magnet motor drives

### Safety in installation, start-up and maintenance

These are additional warnings concerning permanent magnet motor drives. The other safety instructions in this chapter are also valid.

 **WARNING!** Obey these instructions. If you ignore them, injury or death and damage to the equipment can occur.

- Do not work on a drive when a rotating permanent magnet motor is connected to it. A rotating permanent magnet motor energizes the drive including its power terminals.

Before installation, start-up and maintenance work on the drive:

- Stop the motor.
- Disconnect the motor from the drive with a safety switch or by other means.
- If you cannot disconnect the motor, make sure that the motor cannot rotate during work. Make sure that no other system, like hydraulic crawling drives, can rotate the motor directly or through any mechanical connection like belt, nip, rope, etc.
- Measure that the installation is de-energized.
  - Use a multimeter with an impedance of at least 1 Mohm.
  - Make sure that the voltage between the drive output terminals (T1/U, T2/V, T3/W) and the grounding (PE) busbar is close to 0 V.
  - Make sure that the voltage between the drive input power terminals (L1, L2, L3) and the grounding (PE) busbar is close to 0 V.
  - Make sure that the voltage between the drive DC terminals (UDC+, UDC-) and the grounding (PE) terminal is close to 0 V.

- Install temporary grounding to the drive output terminals (T1/U, T2/V, T3/W). Connect the output terminals together as well as to the PE.

Start-up and operation:

- Make sure the motor is not run over the rated speed with dynamic/positive displacement loads.

## General safety in operation

These instructions are for all personnel that operate the drive.

 **WARNING!** Obey these instructions. If you ignore them, injury or death, or damage to the equipment can occur.

- Do not control the motor with the line side disconnect at the drive power supply; instead, use the control panel start and stop keys or commands through the I/O terminals of the drive.
- Give a stop command to the drive before you reset a fault. If you have an external source for the start command and the start is on, the drive will start immediately after the fault reset, unless you configure the drive for pulse start. See the firmware manual.
- Before you activate automatic fault reset functions of the drive control program, make sure that no dangerous situations can occur. These functions reset the drive automatically and continue operation after a fault.

**Note:** When the drive is not in the Hand mode, the Off key on the control panel will not stop the drive.

## Cybersecurity disclaimer

This product is designed to be connected to and to communicate information and data via a network interface. It is Customer's sole responsibility to provide and continuously ensure a secure connection between the product and Customer network or any other network (as the case may be). Customer shall

establish and maintain any appropriate measures (such as but not limited to the installation of firewalls, application of authentication measures, encryption of data, installation of anti-virus programs, etc) to protect the product, the network, its system and the interface against any kind of security breaches, unauthorized access, interference, intrusion, leakage and/or theft of data or information. ABB and its affiliates are not liable for damages and/or losses related to such security breaches, any unauthorized access, interference, intrusion, leakage and/or theft of data or information.

# Contents

This manual is the Installation Manual for the ACS580 Drives. Complete technical details are available in the *ACS580 Hardware manual*, publication number [3AXD50000044794](#). Complete programming information is available in the *ACS580 control program firmware manual*, publication number [3AXD50000016097](#).

To determine the type of your drive, refer to its construction code on either:

- Serial number label attached on upper part of the top mounting plate between the mounting holes.
- Type code label attached to the base frame – on the side of the enclosure.

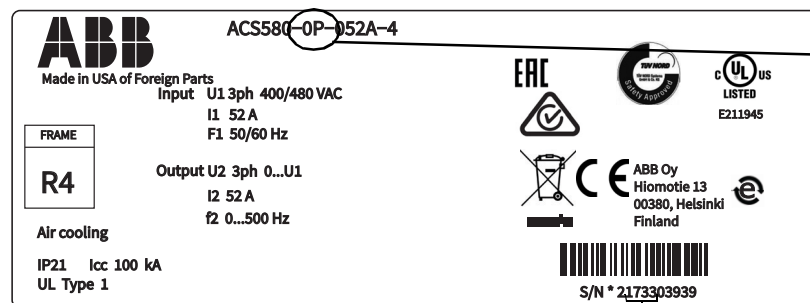

Construction code

Manufacturing year and week

# ACS580-0P

## Installation

This information is unique to ACS580 input disconnect configurations (0P or 0P+F255). The ACS580 with Input Disconnect is an ACS580 AC adjustable frequency drive packaged with an input disconnect switch or circuit breaker. Refer to the [Installation](#) instructions on page 8, for all other information. **Failure to observe the warnings and instructions may cause a malfunction or personal hazard.**



**WARNING!** Before you begin read [Safety instructions](#) on page 2.



**WARNING!** When the ACS580 with Input Disconnect is connected to the line power, the Motor Terminals T1, T2, and T3 are live even if the motor is not running. Do not make any connections when the ACS580 with Input Disconnect is connected to the line. Disconnect and lock out power to the drive before servicing the drive. Failure to disconnect power may cause serious injury or death.

### 1. Install wiring



#### WARNING!

- Metal shavings or debris in the enclosure can damage electrical equipment and create a hazardous condition. Where parts, such as conduit plates require cutting or drilling, first remove the part. If that is not practical, cover nearby electrical components to protect them from all shavings or debris.
- Do not connect or disconnect input or output power wiring, or control wires, when power is applied.
- Never connect line voltage to drive output Terminals T1, T2, and T3.
- Do not make any voltage tolerance tests (Hi Pot or Megger) on any part of the unit. Disconnect motor wires before taking any measurements in the motor or motor wires.
- Make sure that power factor correction capacitors are not connected between the drive and the motor.

Enclosure Designation	Horsepower Range by Voltage Range			Base Drive Frame
	208V	460V	575V <sup>2</sup>	
Px1-1 & Px12-1	1 to 5 HP	1 to 7.5 HP	N/A	R1
Px1-2 & Px12-2	10 HP	10 to 15 HP	2 to 15 HP	R2
Px1-3 & Px12-3	15 to 20 HP	20 to 30 HP	20 to 30 HP	R3
Px1-4 & Px12-4	25 HP	40 to 60 HP	N/A	R4
PxB3R-1	1 to 10 HP	1 to 15 HP	2 to 15 HP	R1-R2
PxB3R-2	15 to 25 HP	20 to 60 HP	20 to 30 HP*	R3-R4
PxB1-3 & PxB12-3	30 to 100 HP <sup>1</sup>	75 to 200 HP	40 to 150 HP	R5-R8

1) 100 HP @ 230V.

\* Only available as ACS580 R2 Frame

\*\* Only available as ACS580 R3 Frame

Connection diagrams – Vertical Packaged Drive with input disconnect

ACS580-0P Vertical Packaged Drive units are configured for wiring access from the bottom only. The following figures show the layout and wiring connection points. For drive control wiring see . Maintain appropriate separation of control and power wires.

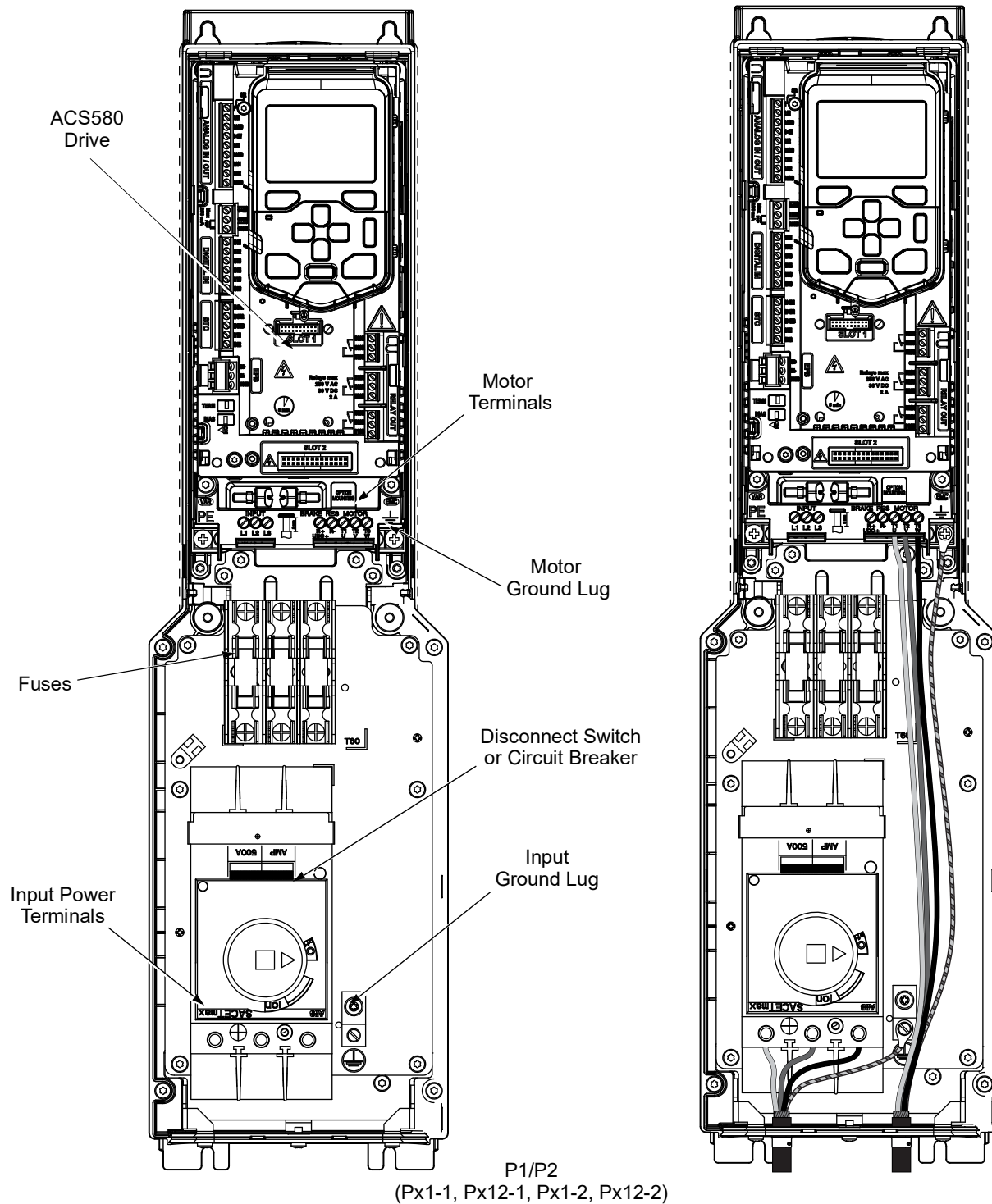

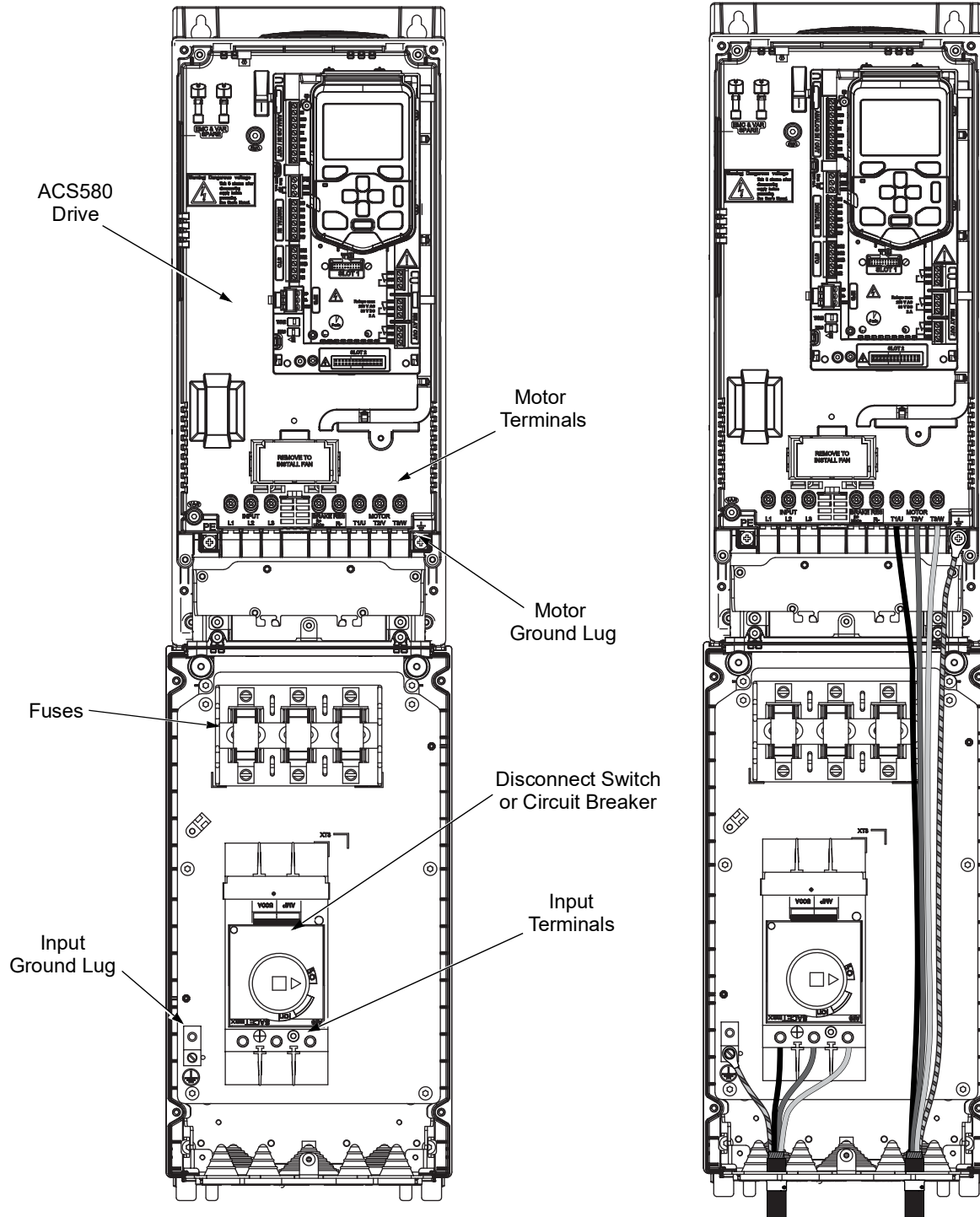

P3/P4  
(Px1-3, Px12-3, Px1-4, Px12-4)



Connection diagrams – Box Packaged Drive with input disconnect

ACH580 Vertical Packaged Drive units are configured for wiring access from the top (for UL (NEMA) Type 1 and 12) and from the bottom (for UL (NEMA) Type 3R). The following figures show the layout and wiring connection points. For drive control wiring see pages 29-41.

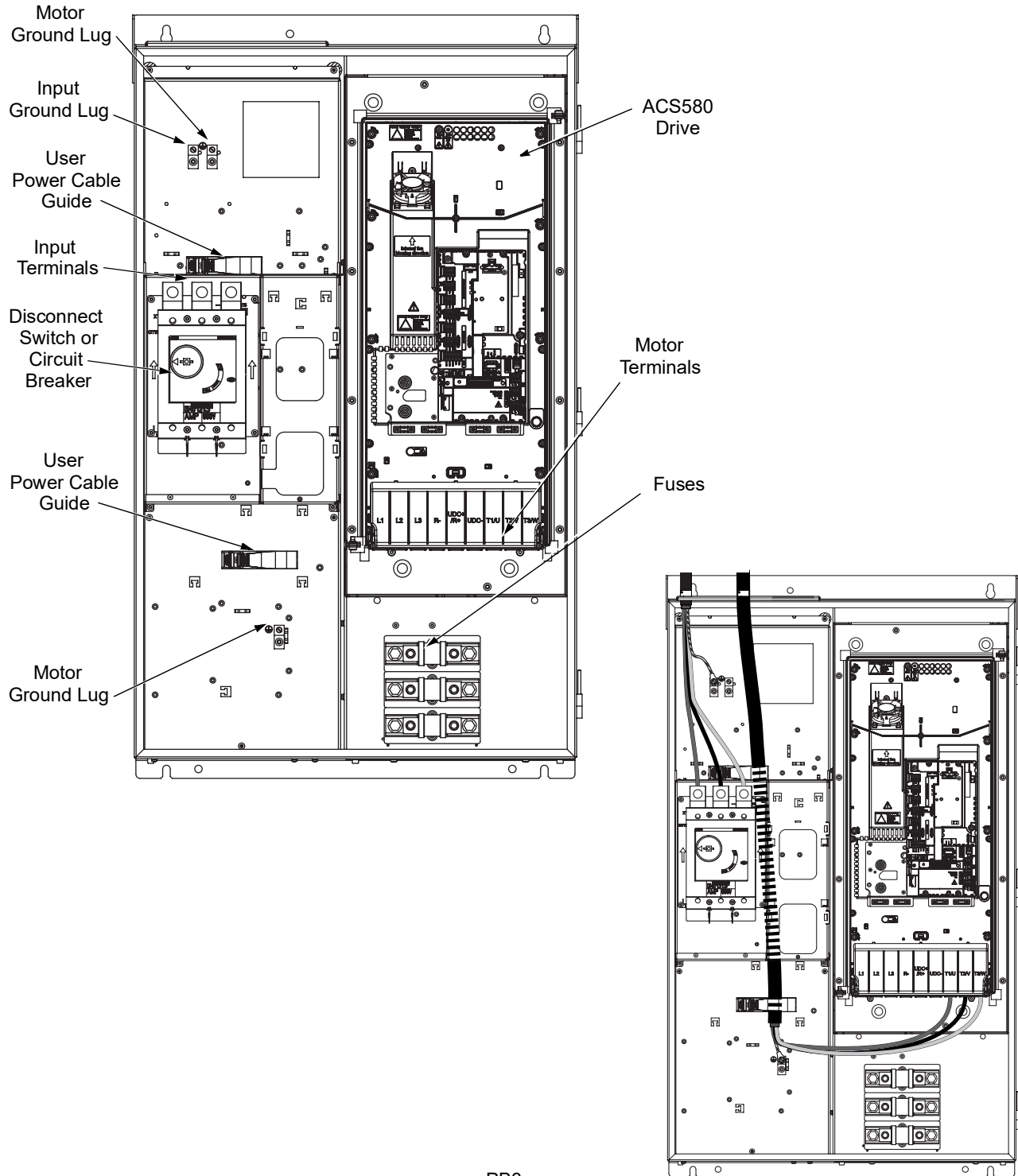

PB3  
(PxB1-3, PxB12-3)

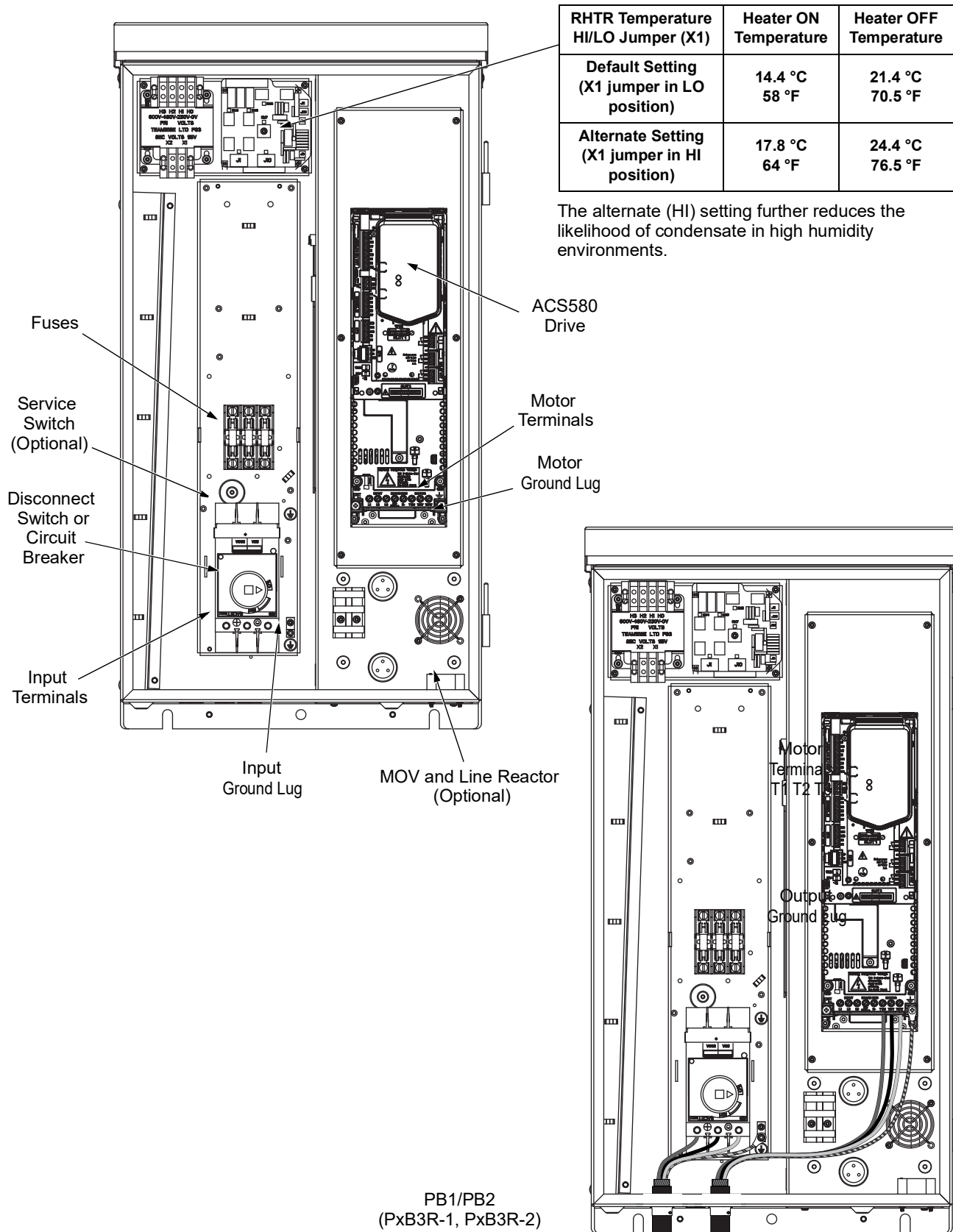

### Power connection terminals

The following tables show maximum wire size and required tightening torque for incoming power, grounding and motor terminals. 1) "0P" represents disconnect and +F255 option code replaces the disconnect with a circuit breaker.

208/230 Volt	Output Ratings		Base Drive Frame Size	Maximum Power Wiring Data					
	A	HP		Circuit Breaker (+F255) UL (NEMA) Type 1 and 12	Circuit Breaker UL (NEMA) Type 3R <sup>3</sup>	Disconnect Switch UL (NEMA) Type 1 and 12	Disconnect Switch UL (NEMA) Type 3R <sup>3</sup>	Motor Terminals	Ground Lugs UL (NEMA) Type 1 and 12
ACS580-0P-04A6-2	4.6	1	R1	#10 62 in-lbs	#10 62 in-lbs	#10 55 in-lbs	#10 55 in-lbs	#10 0.7 ft-lbs	#2 50 in-lbs
ACS580-0P-06A6-2	6.6	1.5	R1						
ACS580-0P-07A5-2	7.5	2	R1						
ACS580-0P-10A6-2	10.6	3	R1	#6 62 in-lbs	#6 62 in-lbs	#6 55 in-lbs	#6 55 in-lbs	#6 1.1 ft-lbs	
ACS580-0P-017A-2	16.7	5	R1						
ACS580-0P-024A-2	24.2	7.5	R2	#4 62 in-lbs	#4 62 in-lbs	#4 55 in-lbs	#4 55 in-lbs	#2 2.6 ft-lbs	
ACS580-0P-031A-2	30.8	10	R2						
ACS580-0P-046A-2	46.2	15	R3	#2 62 in-lbs	#2 62 in-lbs	#2 55 in-lbs	#2 55 in-lbs	#1 3.0 ft-lbs	
ACS580-0P-059A-2	59.4	20	R3						
ACS580-0P-075A-2	74.8	25	R4	#1/0 62 in-lbs	#1/0 62 in-lbs	#1/0 55 in-lbs	#1/0 55 in-lbs	#1 3.0 ft-lbs	
ACH580-PxR-088A-2	88	30	R5						
ACH580-PxR-114A-2	114	40	R5	Consult Factory	Consult Factory	200 MCM 275 in-lbs	Consult Factory	#1/0 50 in-lbs	
ACH580-PxR-143A-2	143	50	R6						
ACH580-PxR-169A-2	169	60	R7						
ACH580-PxR-211A-2	211	75	R7						
ACH580-PxR-248A-2	248	100 <sup>2</sup>	R8						

1) 0P represents a disconnect with fuses. 0P+F255 represents a circuit breaker.

2) 100 HP @ 230V.

3) Only available for packaged drives in box enclosures.

460 Volt	Output Ratings		Base Drive Frame Size	Maximum Power Wiring Data						
	Type Code <sup>1</sup>	A		HP	Circuit Breaker (+F255) UL (NEMA) Type 1 and 12	Circuit Breaker UL (NEMA) Type 3R <sup>2</sup>	Disconnect Switch UL (NEMA) Type 1 and 12	Disconnect Switch UL (NEMA) Type 3R <sup>2</sup>	Motor Terminals	Ground Lugs UL (NEMA) Type 1 and 12
ACS580-0P-02A1-4	2.1	1	R1	#12 62 in-lbs	#12 62 in-lbs	#10 55 in-lbs	#10 55 in-lbs	#10 0.7 ft-lbs	#2 50 in-lbs	
ACS580-0P-03A0-4	3	1.5	R1							
ACS580-0P-03A5-4	3.5	2	R1							
ACS580-0P-04A8-4	4.8	3	R1							
ACS580-0P-07A6-4	7.6	5	R1							
ACS580-0P-012A-4	12	7.5	R1							
ACS580-0P-014A-4	14	10	R2	#10 62 in-lbs	#10 62 in-lbs	#8 55 in-lbs	#8 55 in-lbs	#6 1.1 ft-lbs		
ACS580-0P-023A-4	23	15	R2	#8 62 in-lbs	#6 62 in-lbs	#6 55 in-lbs	#6 55 in-lbs	#2 2.6 ft-lbs		
ACS580-0P-027A-4	27	20	R3			#8 62 in-lbs	#8 62 in-lbs			#4 55 in-lbs
ACS580-0P-034A-4	34	25	R3			#6 62 in-lbs	#6 62 in-lbs	#3 55 in-lbs		#3 55 in-lbs
ACS580-0P-044A-4	44	30	R3			#6 62 in-lbs		#3 55 in-lbs		#3 55 in-lbs
ACS580-0P-052A-4	52	40	R4			#1/0 124 in-lbs		#2 55 in-lbs		#2 55 in-lbs
ACS580-0P-065A-4	65	50	R4			#1/0 124 in-lbs	#1/0 124 in-lbs	#1 55 in-lbs	#1 55 in-lbs	
ACS580-0P-077A-4	77	60	R4	#1/0 124 in-lbs	#1/0 55 in-lbs	#1/0 55 in-lbs				
AC580-Px-096A-4	96	75	R5	#1/0 124 in-lbs	Consult Factory	#3/0 275 in-lbs	Consult Factory	#2/0 4.1 ft-lbs	3 x #3/0 250 in-lbs	
AC580-Px-124A-4	124	100	R6	#2/0 124 in-lbs		250 MCM 275 in-lbs		300 MCM 275 in-lbs		300 MCM 22.1 ft-lbs
AC580-Px-156A-4	156	125	R7	#3/0 124 in-lbs		300 MCM 275 in-lbs		500 MCM 29.5 ft-lbs		
AC580-Px-180A-4	180	150	R7	#4/0 124 in-lbs		2 x 500 MCM 274 in-lbs		2 x 300 MCM 29.6 ft-lbs		
AC580-Px-240A-4	240	200	R8	350 MCM 274 in-lbs						

1) "0P" represents a disconnect with fuses and 0P+F255 represents a circuit breaker.

2) Only available for packaged drives in box enclosures.

575 Volt	Output Range		Base Drive Frame Size	Maximum Power Wiring Data					
	Type Code <sup>1, 2</sup>	A		HP	Circuit Breaker (+F255) UL (NEMA) Type 1 and 12	Circuit Breaker UL (NEMA) Type 3R <sup>4</sup>	Disconnect Switch UL (NEMA) Type 1 and 12	Disconnect Switch UL (NEMA) Type 3R <sup>4</sup>	Motor Terminals
ACS580-0P-02A7-6	2.7	2	R2	#10 62 in-lbs	#10 62 in-lbs	#10 55 in-lbs	#10 55 in-lbs	#6 1.1 ft-lbs	#2 50 in-lbs
ACS580-0P-03A9-6	3.9	3	R2	#12 62 in-lbs	#12 62 in-lbs				
ACS580-0P-06A1-6	6.1	5	R2	#10 62 in-lbs	#10 62 in-lbs				
ACS580-0P-09A0-6	9	7.5	R2						
ACS580-0P-011A-6	11	10	R2						
ACS580-0P-017A-6	17	15	R2	#6 62 in-lbs	#6 62 in-lbs	#6 55 in-lbs	#6 55 in-lbs	#2 2.6 ft-lbs	
ACS580-0P-022A-6	22	20	R3	#4 62 in-lbs	#4 62 in-lbs	#4 55 in-lbs	#4 55 in-lbs		
ACS580-0P-027A-6	27	25	R3						
ACS580-0P-032A-6	32	30	R3	Consult Factory	Consult Factory	#3 55 in-lbs	#2 55 in-lbs	#1 275 in-lbs	
ACH580-PxR-041A-6	41	40	R5						
ACH580-PxR-052A-6 <sup>3</sup>	52	50	R5						#2 62 in-lbs
ACH580-PxR-062A-6	62	60	R6						#1 62 in-lbs
ACH580-PxR-077A-6	77	75	R6						#1/0 62 in-lbs
ACH580-PxR-099A-6	99	100	R7						#3/0 124 in-lbs
ACH580-PxR-125A-6	125	125	R7						250 MCM 124 in-lbs
ACH580-PxR-144A-6	144	150	R8	250 MCM 124 in-lbs	250 MCM 275 in-lbs	500 MCM 29.5 ft-lbs			
								2 x 300 MCM 29.6 ft-lbs	3 x #3/0 250 in-lbs

- 1) 0P represents both a disconnect and 0P+F255 represents a circuit breaker.
- 2) 0P+F255 is rated 600Y/347V unless otherwise specified. For use on a solidly grounded Wye source only.
- 3) 0P+F255 supports Delta network configuration.
- 4) Only available with packaged box enclosures.

### Branch circuit protection

Input power is connected to the ACS580 through a door interlocked disconnect switch or circuit breaker. When connected to a 240V or 480V power source, the ACS580 with the circuit breaker option is suitable for use on a circuit capable of delivering not more than 100,000 RMS symmetrical amperes. When connected to a 600V power source, PC configurations are suitable for use on a circuit capable of delivering not more than 10,000 RMS symmetrical amperes (75-150 HP), and not more than 25,000 RMS symmetrical amperes (2-60 HP).

### Fuses

**Note:** The UL listed drive fuses in the table are provided in the purchased product.

- Replacement fuses are required to be of the same class, current rating, and voltage rating. Fuses from other manufacturers can be used if they are 600V rated and meet the specifications given in the table.
- Fuses with higher current rating than specified must not be used.

### 208 Volt fuses for packaged drive

208 Volt  Type Code <sup>1</sup>	Nominal Output Range		Base Drive Frame Size	Internal Drive Fuse Rating		External Fuse for Disconnect Option	
	Drive Current	Package Power		Class	Current Rating	Class	Max Current Rating
	A	HP					
ACS580-0P-04A6-2	4.6	1	R1	Class CC	15A	N/A	N/A
ACS580-0P-06A6-2	6.6	1.5	R1	Class CC	15A	N/A	N/A
ACS580-0P-07A5-2	7.5	2	R1	Class CC	15A	N/A	N/A
ACS580-0P-10A6-2	10.6	3	R1	Class CC	15A	N/A	N/A
ACS580-0P-017A-2	16.7	5	R1	Class CC	30A	N/A	N/A
ACS580-0P-024A-2	24.2	7.5	R2	Class CC	30A	N/A	N/A
ACS580-0P-031A-2	30.8	10	R2	Class T	40A	N/A	N/A
ACS580-0P-046A-2	46.2	15	R3	Class T	80A	N/A	N/A
ACS580-0P-059A-2	59.4	20	R3	Class T	80A	N/A	N/A
ACS580-0P-075A-2	74.8	25	R4	Class T	100A	N/A	N/A
ACH580-PxR-088A-2	88	30	R5	Class T	110A	N/A	N/A
ACH580-PxR-114A-2	114	40	R5	Class T	150A	N/A	N/A
ACH580-PxR-144A-2	143	50	R6	Class T	200A	N/A	N/A
ACH580-PxR-169A-2	169	60	R7	Class T	250A	N/A	N/A
ACH580-PxR-211A-2	211	75	R7	Class T	300A	Class J or RK1	400A
ACH580-PxR-248A-2	248	100 <sup>2</sup>	R8	Class T	350A	Class J or RK1	400A

1) "0P" represents a disconnect and 0P+F255 represents a circuit breaker.

2) 100 HP @ 230V

## 460 Volt fuses for packaged drive

480 Volt	Nominal Output Range		Base Drive Frame Size	Internal Drive Fuse Rating		External Fuse for Disconnect Option	
	Drive Current	Package Power		Class	Current Rating	Class	Max Current Rating
	A	HP					
ACS580-0P-02A1-4	2.1	1	R1	Class CC	15A	N/A	N/A
ACS580-0P-03A0-4	3	1.5	R1	Class CC	15A	N/A	N/A
ACS580-0P-03A5-4	3.5	2	R1	Class CC	15A	N/A	N/A
ACS580-0P-04A8-4	4.8	3	R1	Class CC	15A	N/A	N/A
ACS580-0P-07A6-4	7.6	5	R1	Class CC	15A	N/A	N/A
ACS580-0P-012A-4	12	7.5	R1	Class CC	15A	N/A	N/A
ACS580-0P-014A-4	14	10	R2	Class CC	30A	N/A	N/A
ACS580-0P-023A-4	23	15	R2	Class CC	30A	N/A	N/A
ACS580-0P-027A-4	27	20	R3	Class T	40A	N/A	N/A
ACS580-0P-034A-4	34	25	R3	Class T	60A	N/A	N/A
ACS580-0P-044A-4	44	30	R3	Class T	60A	N/A	N/A
ACS580-0P-052A-4	52	40	R4	Class T	80A	N/A	N/A
ACS580-0P-065A-4	65	50	R4	Class T	90A	N/A	N/A
ACS580-0P-077A-4	77	60	R4	Class T	100A	N/A	N/A
ACH580-PxR-096A-4	96	75	R5	Class T	150A	N/A	N/A
ACH580-PxR-124A-4	124	100	R6	Class T	200A	N/A	N/A
ACH580-PxR-156A-4	156	125	R7	Class T	225A	N/A	N/A
ACH580-PxR-180A-4	180	150	R7	Class T	300A	N/A	N/A
ACH580-PxR-240A-4	240	200	R8	Class T	350A	Class J or RK1	400A Max

1) "0P" represents a disconnect and 0P+F255 represents a circuit breaker.

## 575 Volt fuses for packaged drive

575 Volt	Nominal Output Range		Base Drive Frame Size	Internal Drive Fuse Rating		External Fuse for Disconnect Option	
	Drive Current	Package Power		Class	Current Rating	Class	Max Current Rating
	A	HP					
ACS580-0P-02A7-6	2.7	2	R2	Class CC	15A	N/A	N/A
ACS580-0P-03A9-6	3.9	3	R2	Class CC	15A	N/A	N/A
ACS580-0P-06A1-6	3.5	6.1	R2	Class CC	15A	N/A	N/A
ACS580-0P-09A0-6	4.8	9	R2	Class CC	15A	N/A	N/A
ACS580-0P-011A-6	7.6	11	R2	Class CC	30A	N/A	N/A
ACS580-0P-017A-6	17	15	R2	Class CC	30A	N/A	N/A
ACS580-0P-022A-6	22	20	R3	Class T	40A	N/A	N/A
ACS580-0P-027A-6	27	25	R3	Class T	40A	N/A	N/A
ACS580-0P-032A-6	32	30	R3	Class T	40A	N/A	N/A
ACH580-PxR-041A-6	41	40	R5	Class T	50A	N/A	N/A

575 Volt	Nominal Output Range		Base Drive Frame Size	Internal Drive Fuse Rating		External Fuse for Disconnect Option	
	Drive Current	Package Power		Class	Current Rating	Class	Max Current Rating
	A	HP					
ACH580-PxR-052A-6 <sup>3</sup>	52	50	R5	Class T	80A	N/A	N/A
ACH580-PxR-062A-6	62	60	R5	Class T	80A	N/A	N/A
ACH580-PxR-077A-6	77	75	R5	Class T	100A	N/A	N/A
ACH580-PxR-099A-6	99	100	R7	Class T	150A	N/A	N/A
ACH580-PxR-125A-6	125	125	R7	Class T	175A	N/A	N/A
ACH580-PxR-144A-6	144	150	R8	Class T	200A	N/A	N/A
ACH580-PxR-180A-4	180	150	R2	Class T	300A	N/A	N/A
ACH580-PxR-240A-4	240	200	R2	Class T	350A	Class J or RK1	400A Max

- 1) "0P" represents a disconnect and 0P+F255 represents a circuit breaker.
- 2) ACS580-0P-xxxx-x+F255 is rated 600Y/347V unless otherwise specified. For use on a solidly grounded Wye source only.
- 3) ACS580-0P-xxxx-x+F255 supports Delta network configuration.



## Operation

This information is unique to ACS580 input disconnect configurations (0P). Refer to the [Operation](#) instructions on page 45 for all other information.

### Input disconnect configuration

The ACS580 with Input Disconnect is an ACS580 AC adjustable frequency drive packaged with an input disconnect switch or circuit breaker, and with a door interlocked, external operating handle. The operating handle can be padlocked in the OFF position (padlock not supplied). Enclosure options are UL (NEMA) Type 1UL (NEMA) Type 12 (NEMA 1 NEMA 12).

The following is a typical power diagram.

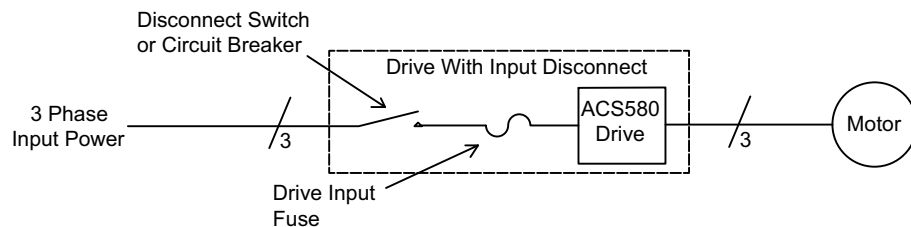

The following shows the front view of the ACS580 Vertical Packaged Drive configuration and identifies the major components.

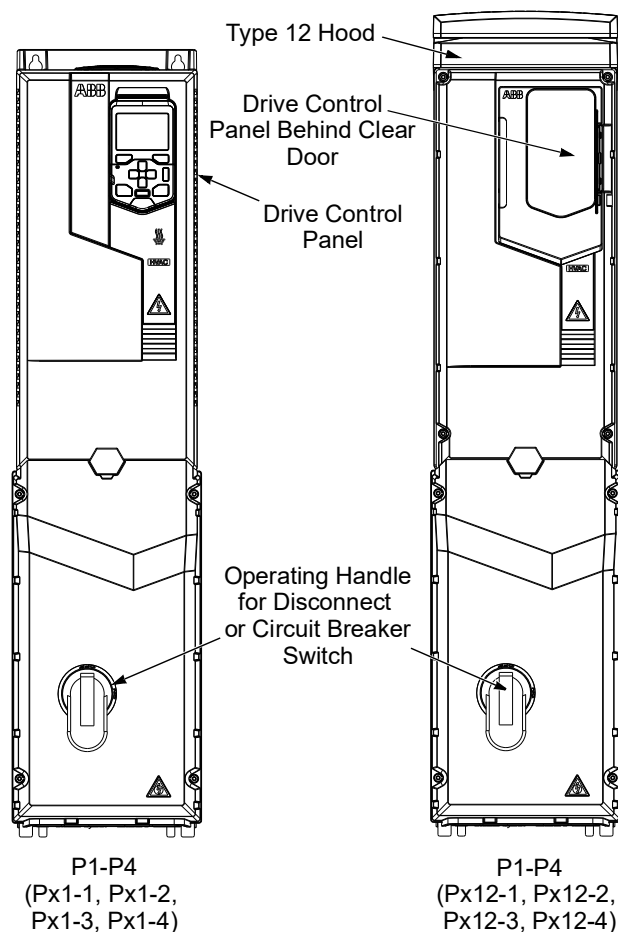

# Dimensions

## P1 Type 1

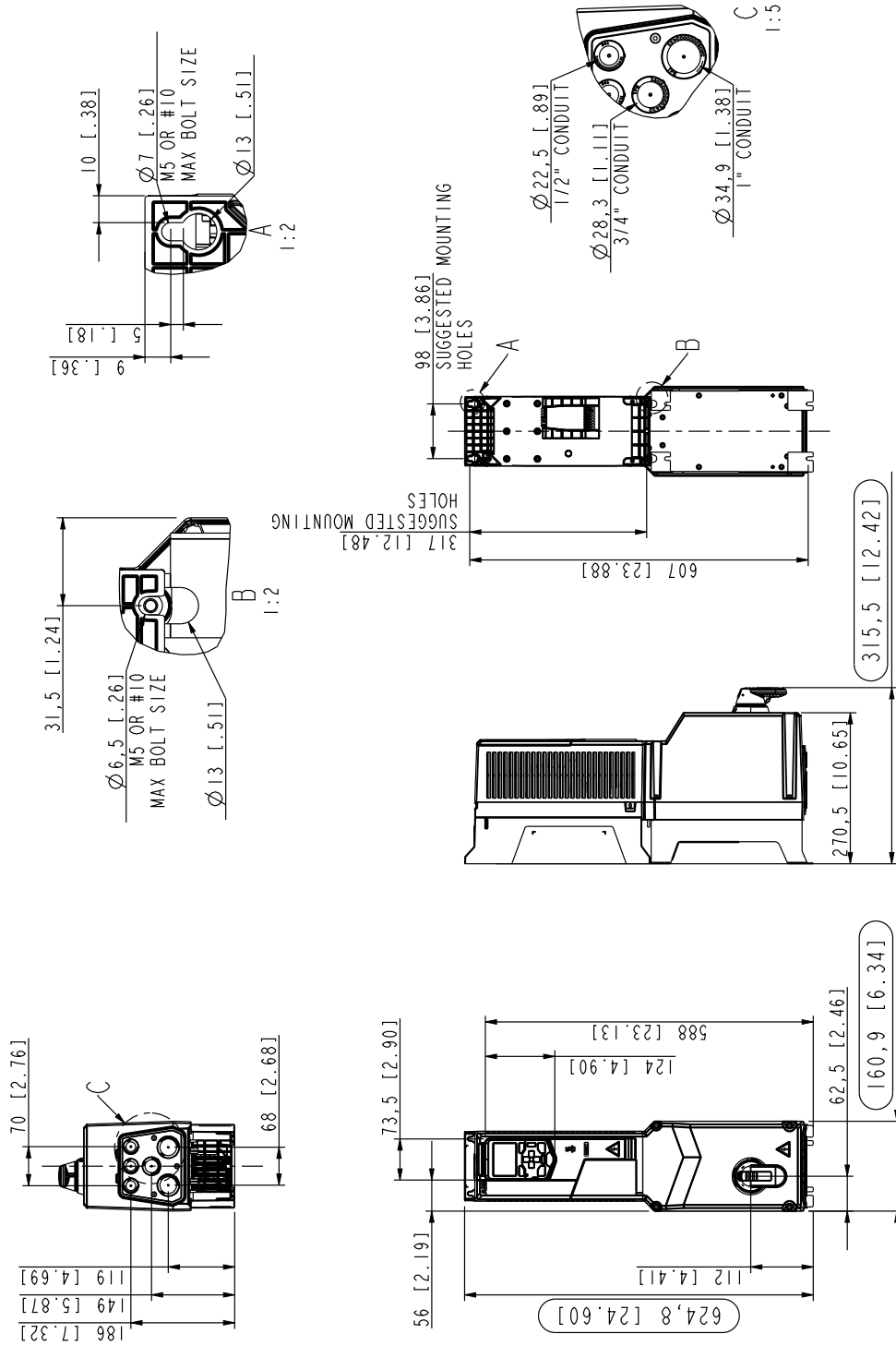

P1 Type 12

TYPE 12

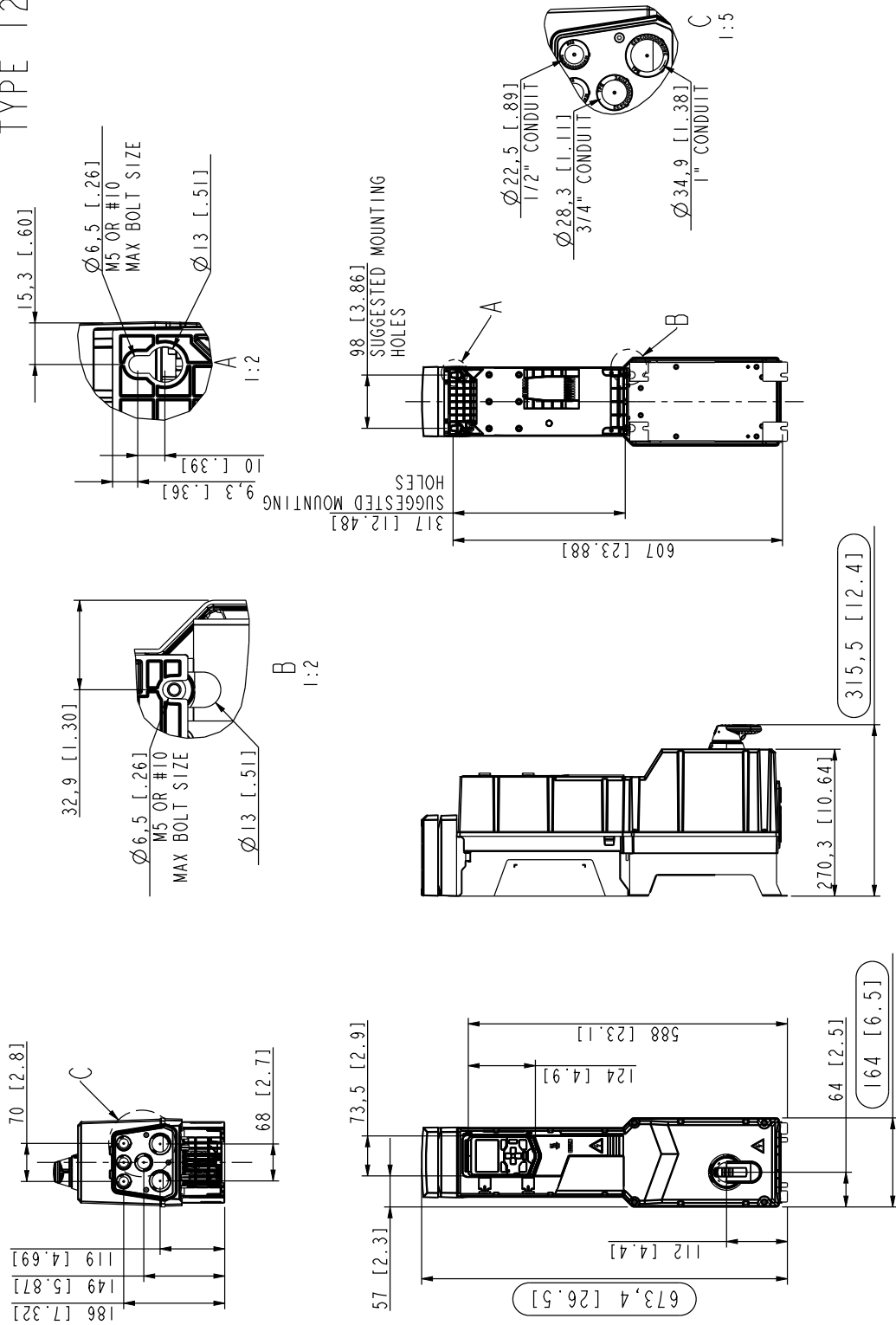

P2 Type 1

TYPE I

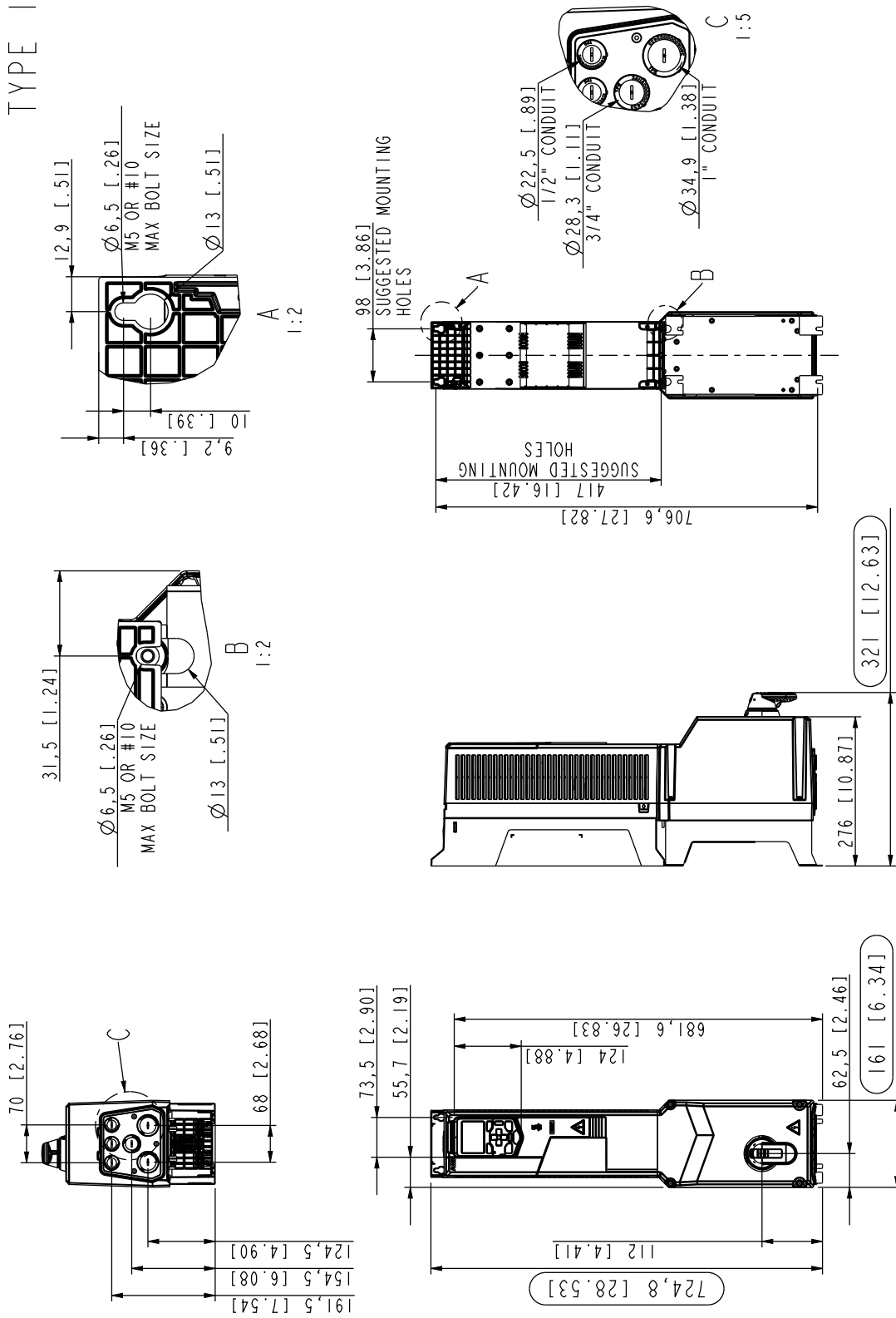

TYPE 12

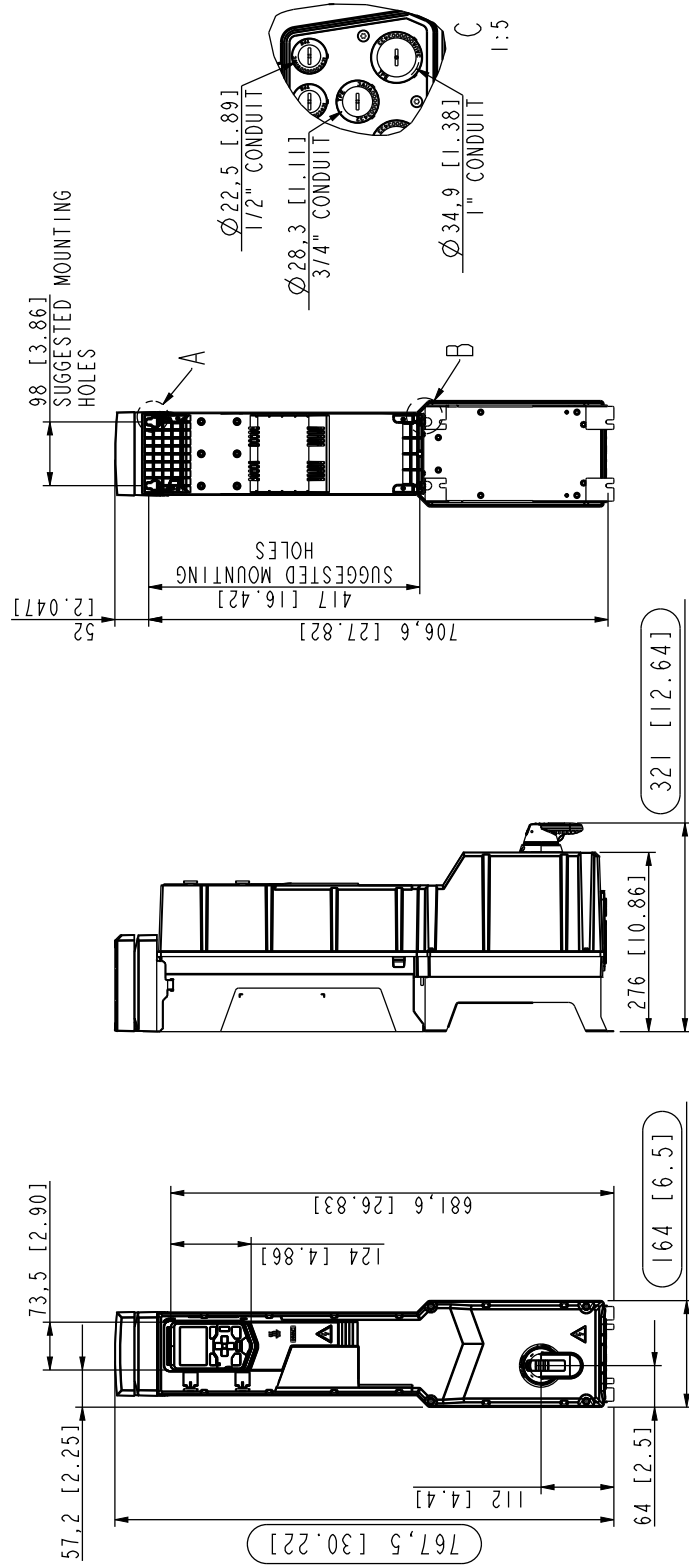
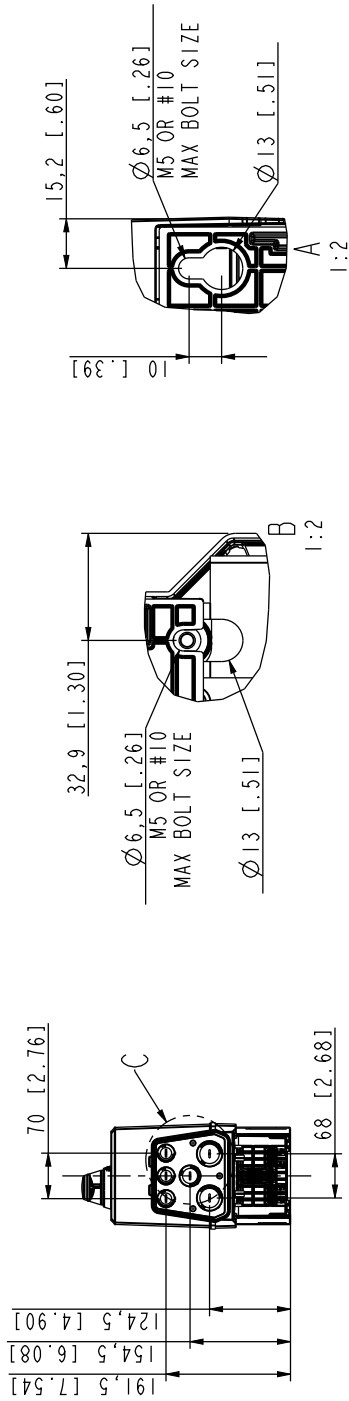

P3 Type 1

TYPE I

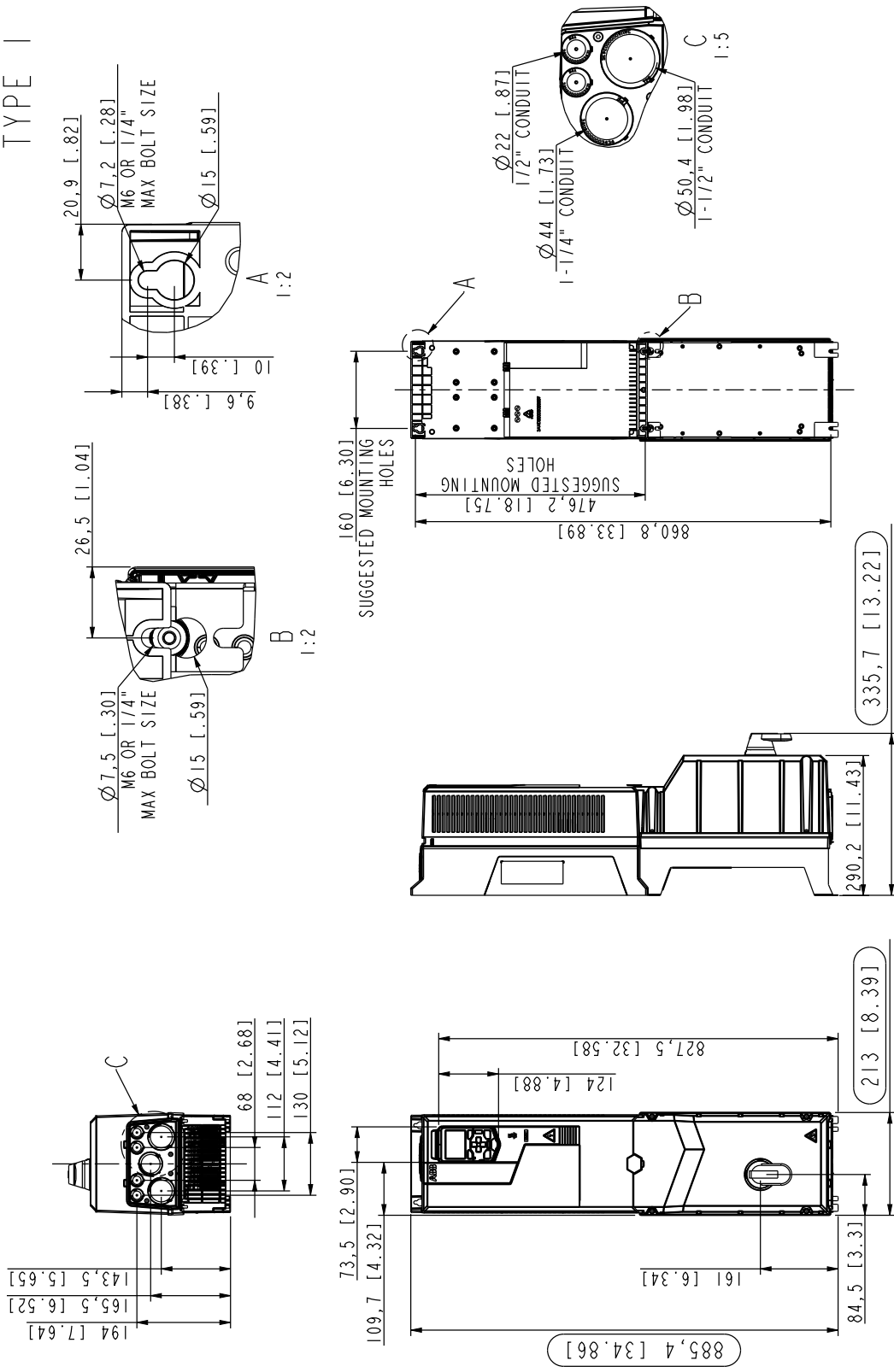

P3 Type 12

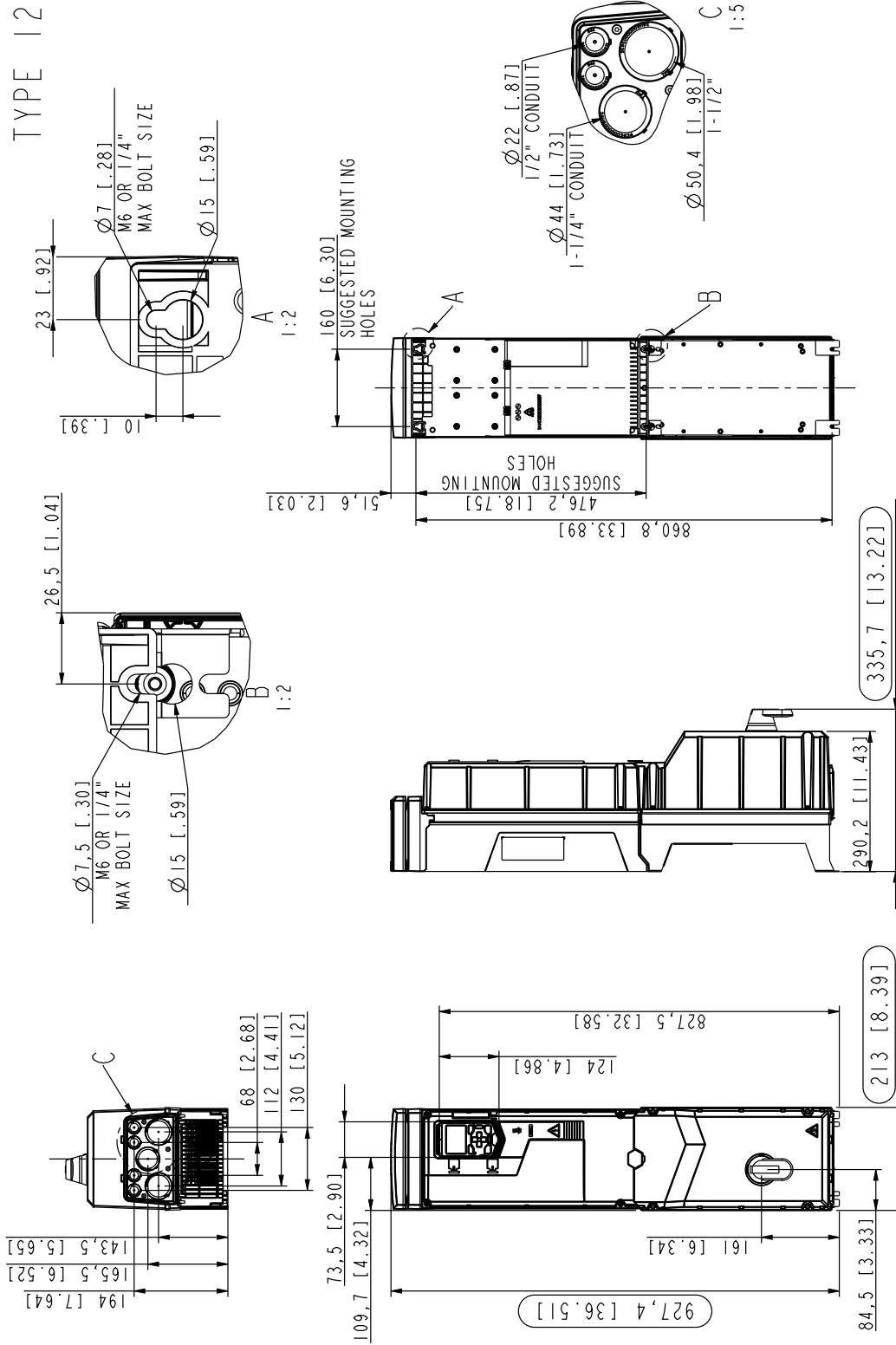

P4 Type 1

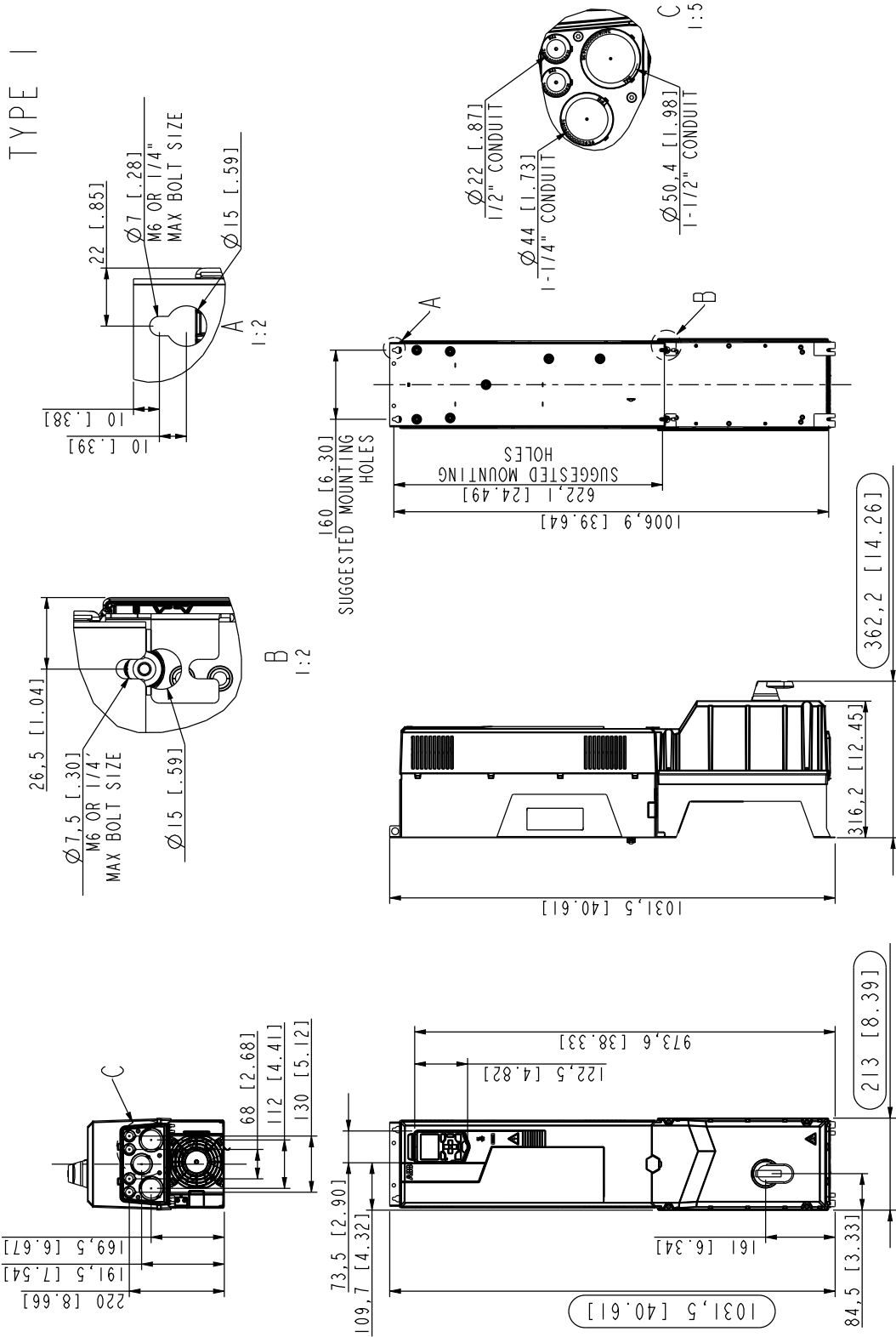



P4 Type 12

TYPE 12

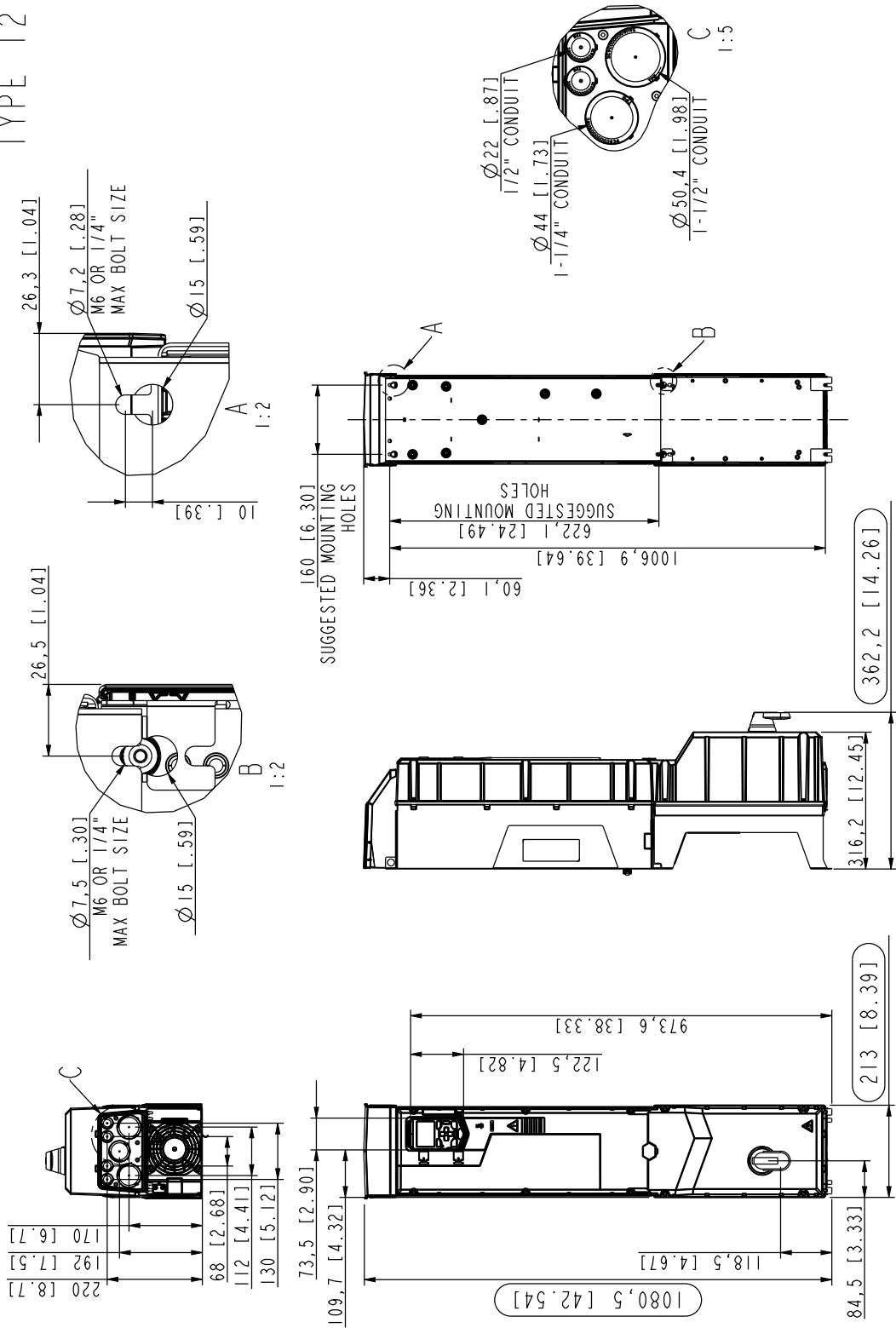



**PB2 Type 3R**

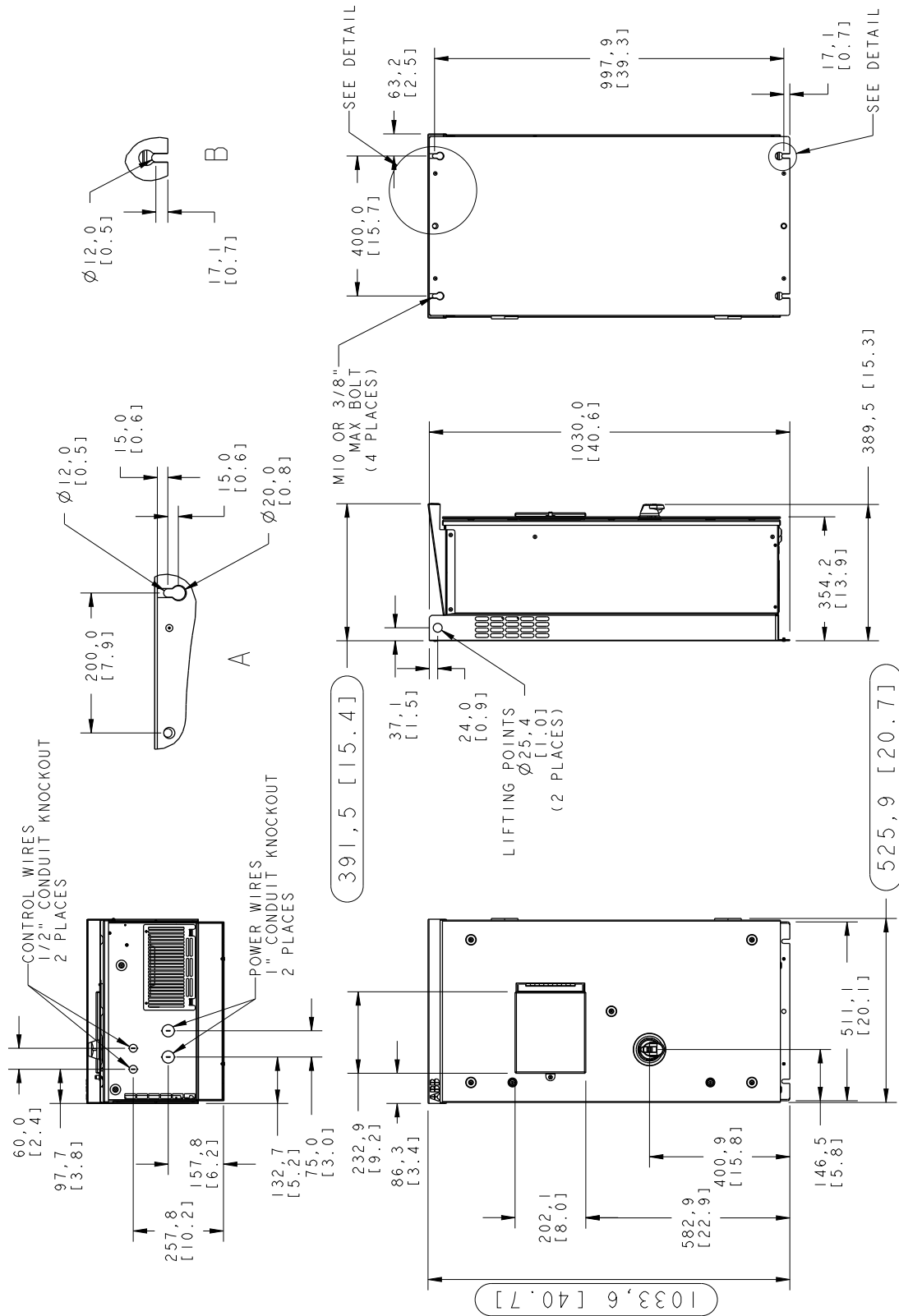

**PB3 Type 1**

TYPE I

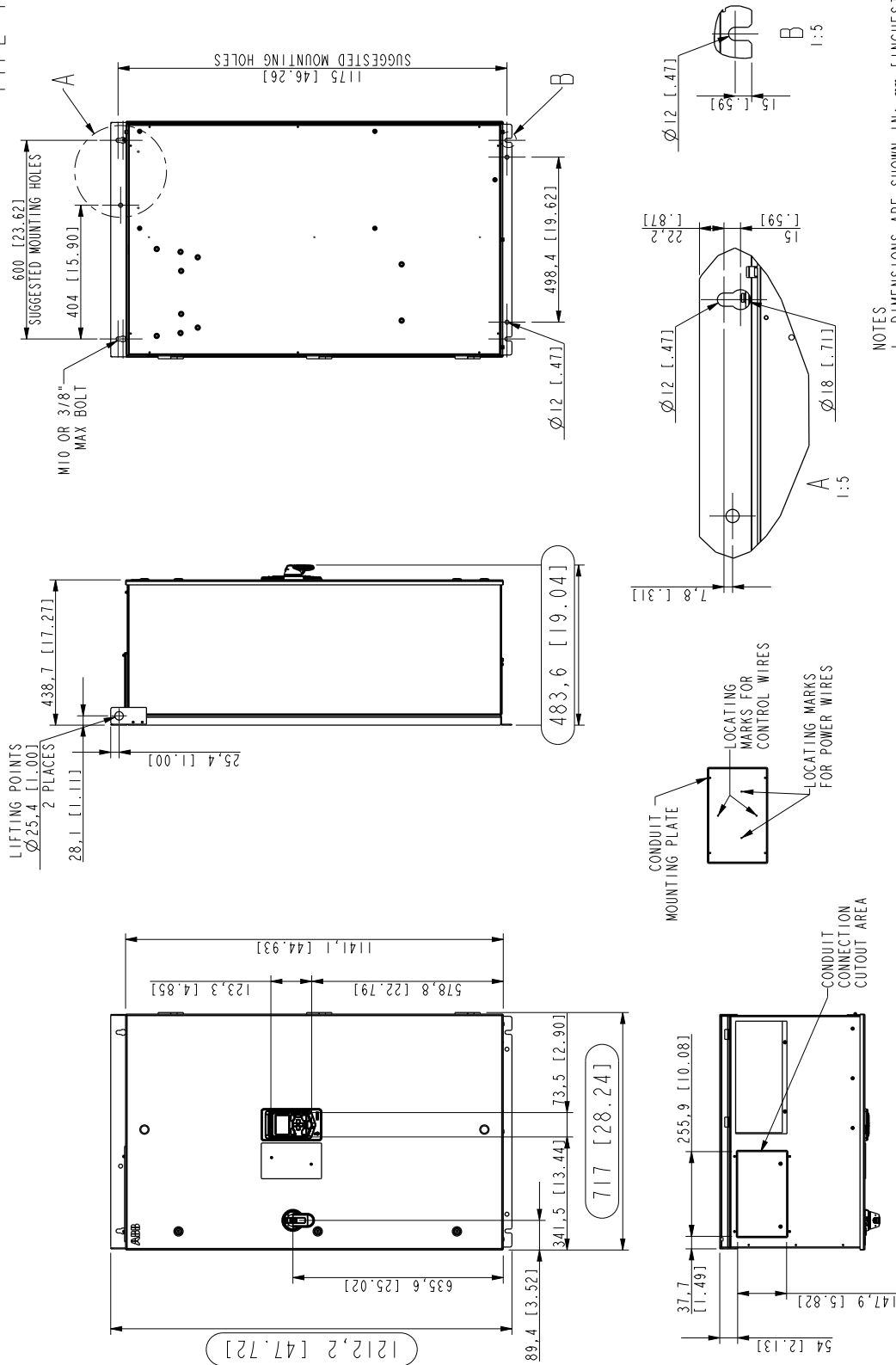

NOTES  
1. DIMENSIONS ARE SHOWN IN: mm [INCHES]



*[Page intentionally left blank]*





3AXD50000460113REVB  
Effective: 09-27-2019  
Supersedes:

---

**ABB Inc.**

16250 West Glendale Drive

New Berlin, WI 53151

USA

Telephone +1 800 752-0696

Fax +1 262 785-0397

Internet [www.abb.com/drives](http://www.abb.com/drives)