



PROGRAMMING PRIMER TYPE 45FS1/45UVFS1 MODEL 1000, 1001 FLAME SIGNATURE SCANNER™

SCOPE

This document is an outline on how to program the FIREYE® *Signature Scanner*.™ It is not intended to be full in scope, but rather to serve as primer to the complete scanner bulletin (publication number CU-32). Carefully read all documentation before using the scanner.

SCANNER OPERATION

The 45FS1/45UVFS1 software operates like most computer software. To program the scanner, a file is created, saved, and run. A file consists of configuration data and the learned flame-on/off signature data. A factory file “F” is shipped with the scanner which can be used as a starting place. After a file has been saved it can be loaded, edited and resaved. The files are saved in non volatile memory—no battery is required.

The *Signature Scanner* flame detector has four push-buttons for configuring and programming the scanner. See Page 6. Three of the push-buttons are located on the front of the scanner: Advance, Help, and Change.

1. ➔ Advance— used to advance through the menus
2. ? Help – used to explain and expand abbreviations
3. ▲ Change – used to change setpoints within a menu

The fourth pushbutton **Program Enable** is located underneath the side access plate. A screwdriver is required for access. The cover prevents unauthorized personal from changing setpoints.

4. **Program Enable** used to execute or program certain menu setpoints.

NOTICE

When Fireeye products are combined with equipment manufactured by others and/or integrated into systems designed or manufactured by others, the Fireeye warranty, as stated in its General Terms and Conditions of Sale, pertains only to the Fireeye products and not to any other equipment or to the combined system or its overall performance

SCANNER MENUS

The *Signature Scanner* flame detector has two levels of menus: the status menu and the setpoints (or programming) menu. See Page 7. The status menu displays the scanner's status; e.g. whether the flame is on or off, the scanner's internal temperature etc. When power is applied to the scanner it defaults to the status menu.

The programming menu is used to configure the scanner and learn flame signatures, etc. The **Program Enable** key must be pressed to enter the programming menu.



HOW TO PROGRAM THE SCANNER

The Flame Signature is easily programmed through simple menu selections. As you advance through the menus, simply select the setpoint that best describes your application.

There are eight (8) steps in programming the Signature Scanner.

1. Put the scanner in the programming menu.
2. Edit File F to enable the automatic gain control to send out pulses to the flame amplifier to energize the flame relay.
3. Configure a file for fuel type, burner type, etc.
4. Aim the scanner.
5. Learn *flame-on* signature
6. Learn *flame-off* signature (multi burner background flames)
7. Save the file (configuration and signature data)
8. Run the file

STEP 1

Put the Scanner in the Programming Mode:

After power has been applied to the scanner, press the **Program Enable** pushbutton located behind the side access plate. (screwdriver required) The first programming menu item displayed is EDIT NO. Press the change key (▲) to display EDIT YES. Then press the Advance key (➡) to continue.

STEP 2

Edit File F

This step enables the automatic gain control function to send pulses to the flame amplifier with a minimum amount of flame present in order to energize the flame relay.

With EDIT A (or appropriate file) displayed, use the change key (▲) to display EDIT F and then press the **Program Enable** button.

Use the Advance key (➡) until the Burner Type setpoint **B = OFF** is displayed. Use the change key (▲) to change this setpoint to the value that best describes your particular application.

As soon as the value for the setpoint Burner Type changes from OFF, the scanner should start to send pulses to the flame amplifier, provided some source of flame signal is present.

***NOTE:** When model 45UVFS1 scanner is used it may be necessary to perform a "Gain Calibration" (Step 4) before the scanner sends pulses to the amplifier.*



STEP 3

Configure the Scanner:

The following nine (9) setpoints are used to configure the scanner. The values of these setpoints are changed by pressing the ▲ key. Advance through each setpoint by pressing the advance key ➡ and select the value that best describes your particular application. Advancing to the next menu item retains the selected value.

MENU ITEM- DESCRIPTION (See Bulletin CU-32 for more information)

- | | |
|---------------|--|
| 1. COMM = 1 | Communication Address |
| 2. FFRT = 3 | Flame failure response time in seconds ^{1,2} |
| 3. BFRT = 3 | Background failure response time in seconds ² |
| 4. OTD = 2 | On-time delay in seconds |
| 5. T = 25 C | Internal scanner temperature |
| 6. F = GAS | Fuel types: gas, other, oil, coal |
| 7. B = LOWNOX | Burner types: gun, lownox, ring, cane, etc. |
| 8. AMP = 5000 | Amplifier series type;example:5000 = 5011,5012 |
| 9. RFS = OFF | Remote file select |

STEP 4

Aim the scanner:

After the scanner has been configured, the tenth (10) menu item is the setpoint Aim; **AIM = 30**. (Or appropriate value)

With the burner flame ON, ³ point the scanner at the front portion of flame. Next, press the **Program Enable** push-button. This will initiate a gain calibration. The display shows **GAIN CAL**. When the calibration is complete the display will return to **AIM = 30**, (for example). The scanner is now ready to be aimed more precisely.

Move the scanner **SLOWLY** from one position to another and note the **AIM** number displayed. Wait a few seconds after each new position. The **LOWEST** aim number is best. After the lowest number is found, securely fasten the scanner to prevent any further movement.

NOTE: If a very negative "AIM" number is displayed at the scanner (e.g. -20) the scanner may periodically indicate "FLAME-OFF" when a valid flame is present. The selection "MECH" as a burner "TYPE" (Step 3.7) will correct this.

STEP 5

Learn the flame-on characteristics:

Press the Advance key ➡ until **L ON NEW** appears.

*NOTE: The Change key ▲ will toggle back and forth between **L ON NEW** and **L ON ADD**.*

¹Response time of the scanner is additive to the amplifier: e.g. if FFRT in scanner = 3 seconds, and FFRT in amplifier = 1 second, then total response time = 4 seconds.

²**FFRT** is Flame Failure Response Time. This is the response time of the scanner to react to a total "FLAME-OUT" without background flames present.

BFRT is Background Failure Response Time. This is the response time of the scanner to react to a flame-out with background flames present.

³Ideally, the scanner should learn the "worst-case" or least stable, "FLAME-ON" conditions. For many burners this is at low fuel loading conditions. Not all burners are alike: consult the burner manufacturer or test the burner to determine worst-case conditions.



CAUTION: During L ON NEW or L ON ADD, all boiler variables should be held steady within reason (e.g. do not vary firing rate or bucket tilt). Also, do not change the variables of adjacent burner.

With the burner flame ON¹, press the **Program Enable** push-button to start the learn mode. The scanner will do a gain calibration (again). The display shows **GAIN CAL**.

The screen will then display:

LRN = 110 and start to count down.

When the display reaches 100, the screen displays:

NEW DATA and then continues to count down.

If certain conditions change in the monitored flame during *Learn Flame On*, the screen will again display **NEW DATA**, reset to 100, and then continue to count down from 100.

When the countdown reaches 0, the screen displays:

LEARN ON COMPLETE

Without interruptions, it will take approximately 50 seconds for *Learn "FLAME-ON"* to count down to 0 (**NEW DATA** only displayed once). However, it will typically take 2-4 minutes to read the "*FLAME -ON*" signature profile, allowing for additional **NEW DATA** reads.

STEP 6

Learn the "FLAME -OFF" characteristics:

This function is used to learn the signature of any background radiation present in single-burner and multi-burner applications. Multi-burner background radiation is comprised of the flames of adjacent and opposite burners. Single-burner background may be comprised of other infrared or ultraviolet sources combined with dust, as in a kiln application.

Press the Advance key ➡ until **L OFF NEW** appears.

NOTE: The Change key ▲ will toggle back and forth between L ON NEW and L ON ADD.



CAUTION: During L OFF NEW or L OFF ADD, all boiler variables should be held steady within reason (e.g. do not vary firing rate or bucket tilt). Also, do not change the variables of adjacent burners.

With the burner flame OFF, and all adjacent burners ON², press the **Program Enable** push-button to start the learn mode. The learn counter will start to count down from 110 to 0. The display shows **LRN = 110** and starts to count down.

When the display reaches 100, the screen displays:

NEW DATA and then continues to count down.

If certain conditions in the monitored flame change during *Learn "FLAME-OFF"*, the screen will again display **NEW DATA**, reset to 100, and then continue to count down from 100.

When the countdown reaches 0, the screen displays:

¹Ideally, the scanner should learn the "worst-case" or least stable, "FLAME-ON" conditions. For many burners this is at low fuel loading conditions. Not all burners are alike: consult the burner manufacturer or test the burner to determine worst-case conditions.

²Ideally, the scanner should learn the "worst-case" "FLAME-OFF" conditions. For many furnaces this is at high loading or maximum output capacity (all burners on). Not all furnaces are alike: consult the furnace manufacturer or test the furnace to determine worst-case conditions.



LEARN OFF COMPLETE

Without interruptions, it will take approximately 50 seconds for *Learn* “FLAME-OFF” to count down to 0 (NEW DATA only displayed once). However, it will typically take 2-4 minutes to read the “FLAME-OFF” signature profile, allowing for additional NEW DATA reads.

STEP 7

Save the configuration and signature data to a file:

Advance to the **SAVE** menu item. The configuration and learned signature data must be saved to one of three files; A or B or C. Select the file by pressing the **▲** key then press the **Program Enable** key to save the data.

STEP 8

Run the file:

Advance to the **RUN** menu item. Select the file (A,B,C) where the data was saved by pressing the **▲** key. Press the **Program Enable** key to run that file. The scanner will now run the configuration and learned signature data in steps 1-8. The scanner then returns to the status menus.

Advance in the status menus until **DISCR = 7** (or appropriate value). **DISCR** is the discrimination between “FLAME-ON” and “FLAME-OFF”. Possible discrimination numbers range from 9 (the best) to 0. (A discrimination number of “9” will be displayed until a “Learn Flame OFF new” procedure is performed). Discrimination numbers between “6” and “9” are common. Very low discrimination numbers (0, 1, 2) *may* result in poor scanner performance. Low discrimination numbers may indicate improper programming procedures, or may require that the scanner be re-aligned for an improved view of the target flame.



CAUTION: With *any* discrimination value the burner and scanner must be tested by stopping and starting the burner several times to insure the proper operation of the scanner (e.g. screen correctly displays “FLAME-ON” or “FLAME-OFF” to reflect actual conditions.) as well as the response time of the scanner.

NOTE: Total FFRT time is the sum of the FFRT time of both the 45FS1/45UVFS1 and the flame amplifier.

This testing should be done with various adjacent burners on and off and at various load levels. This is the only way to ensure proper operation

ADD TO FLAME SIGNATURE DATA

It may be necessary to add to an existing flame signature under several burner conditions (e.g. various firing rates of both the monitored and adjacent burners) in order to improve flame detection and discrimination.

To add to existing “FLAME-ON” or “FLAME-OFF” signatures, select the appropriate file to edit and press the Advance key **➡** until **L ON ADD** (for *flame on* signature) or **L OFF ADD** (for “FLAME-OFF” signature) appears and then repeat Step 5 (for “FLAME-ON” signature) or Step 6 (for “FLAME-OFF” signature).

FLAME SIGNATURE SCANNER

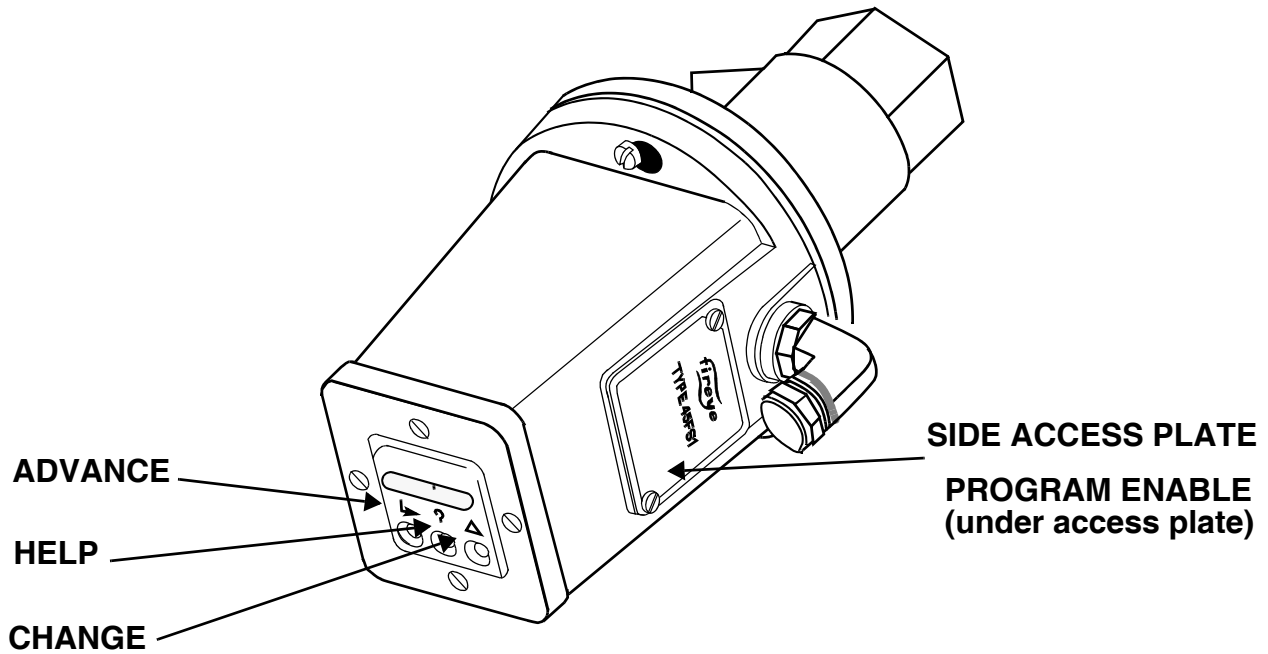

STATUS MENU LOOP (Except for temperature, all values shown are factory default setting)

Keypad Legend

- Advance (Advances menu)
- Help (Scrolls descriptor)
- Change (Not functional in status loop)
- Program Enable (Executes commands)

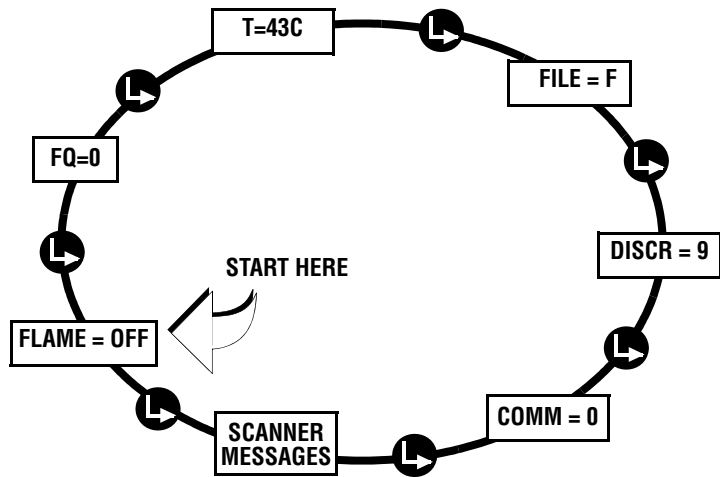

MNEMONIC CODE	DESCRIPTION	ALLOWABLE VALUES
Flame OFF	The status of the monitored flame	Flame on/Flame off
FQ = 0	Flame quality	0-100
T = 43 C	Internal flame scanner temperature	Celsius or Fahrenheit
FILE = F	Reference flame signature file	A, B, C, F, (:), (*)
DISCR = 9	Flame on/ flame off discrimination ratio	0-9
COMM = 0	Communication Address	0-127
Scanner Messages	Will display any scanner messages, errors, or revision number.	See "Scanner Messages"

SETPOINT MENU LOOP (All values shown are factory default setting)

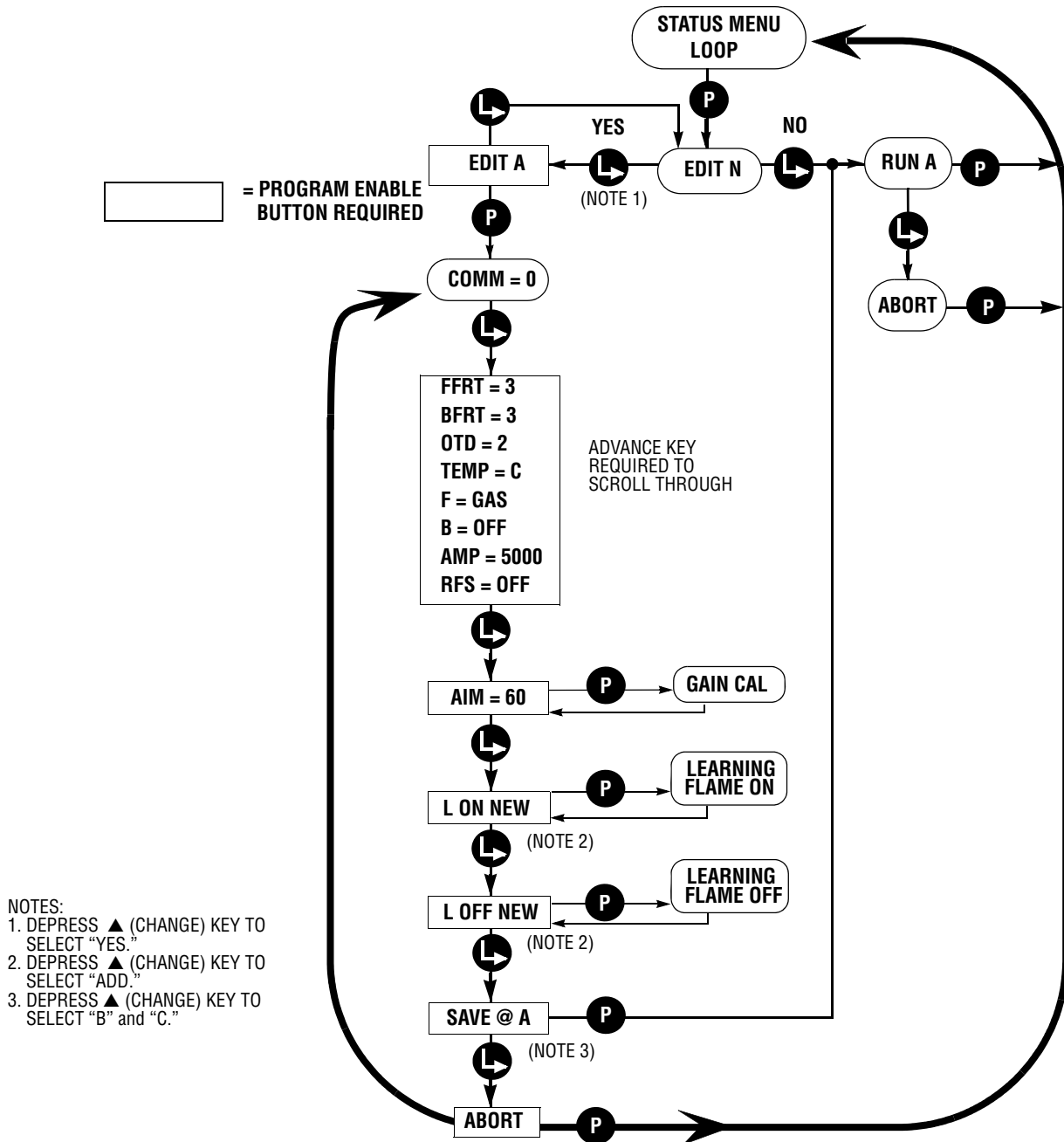

MNEMONIC CODE	DESCRIPTION	ALLOWABLE VALUES
EDIT N	Edit a file	Yes, No (Note 1)
EDIT A	Select the file to edit	A, B, C, F
COMM = 0	Communication Address	0 - 127
FFRT = 3	Flame failure response time	1-6 seconds
BFRT = 3	Background failure response time	2-8 seconds (Note 2)
OTD = 2	On time delay	2-4 seconds
TEMP = C	Temp displayed in Celsius (or Fahrenheit)	Celsius or Fahrenheit



MNEMONIC CODE	DESCRIPTION	ALLOWABLE VALUES
F = GAS	Type of fuel	Gas, other, oil, coal
B = OFF	Type of burner	Off, mech, gun, lownox, cane, ring, bucket, grate, other
AMP = 5000	Type of amplifier	Series 5000, R900, 2000, 4000 amplifiers
RFS = OFF	Remote file select	Off, On, Comm
(Last six functions require activation of button to execute: Aim - Abort)		
AIM = 60	Scanner sighting aid	
L ON NEW	Learn a new flame-on signature	(Note 3)
L ON ADD	Learn and add to an existing flame-on signature	
L OFF NEW	Learn a new flame-off signature	(Note 3)
L OFF ADD	Learn and add to an existing flame-off signature	
SAVE@A	Save the flame signature to a file	File A, B, or C (Note 4)
RUN A	Run the flame signature in a file	File A, B, C, or F (Note 5)
ABORT	Abort program mode; return to Status Menu	
1. Depress ▲ (change) to select "yes" 2. BFRT cannot be set less than FFRT. 3. Depress ▲ (change) to select "ADD." 4. Depress ▲ (change) to select "B, C" 5. Depress ▲ (change) to select "B, C, F."		

NOTICE

When Fireeye products are combined with equipment manufactured by others and/or integrated into systems designed or manufactured by others, the Fireeye warranty, as stated in its General Terms and Conditions of Sale, pertains only to the Fireeye products and not to any other equipment or to the combined system or its overall performance.

WARRANTIES

FIREYE guarantees for *one year from the date of installation or 18 months from date of manufacture* of its products to replace, or, at its option, to repair any product or part thereof (except lamps, electronic tubes and photocells) which is found defective in material or workmanship or which otherwise fails to conform to the description of the product on the face of its sales order. **THE FOREGOING IS IN LIEU OF ALL OTHER WARRANTIES AND FIREYE MAKES NO WARRANTY OF MERCHANTABILITY OR ANY OTHER WARRANTY, EXPRESS OR IMPLIED.** Except as specifically stated in these general terms and conditions of sale, remedies with respect to any product or part number manufactured or sold by Fireeye shall be limited exclusively to the right to replacement or repair as above provided. In no event shall Fireeye be liable for consequential or special damages of any nature that may arise in connection with such product or part.



FIREYE®
 3 Manchester Road
 Derry, New Hampshire 03038 USA
 www.fireeye.com

CU-33
 APRIL 5, 2013
 Supersedes May 8, 2006